



Global Assessment of:

Pacific Rim Wood Ltd

FLAMEBREAK

60 Minute Fire Resisting Doorsets

Report No: FEA/F02141 Revision F

**Issue Date: 19 July 2010
Valid Until: 22 August 2012**



committed to excellence

Prepared for:

**Pacific Rim Wood Ltd
Unit 3
Kingdom Fields
Bratton Fleming
Barnstaple
EX31 4EN**

www.chilternfire.co.uk

www.chilterndynamics.co.uk

www.qmark.info

This document is confidential and remains the property of Chiltern International Fire Ltd. The legal validity of this report can only be claimed on the presentation of the complete report.

Contents

	Page No
1 Introduction	3
2 General Description of Construction	3
3 Leaf Sizes	4
4 Configurations	4
5 Leaf Size Adjustment	4
6 Overpanels	4
7 Glazing	5
8 Facing Materials	7
9 Lippings	8
10 Door Frames	8
11 Intumescent materials	9
12 Adhesives	11
13 Tested Hardware	11
14 Additional & Alternative Hardware	11
15 Door Gaps	14
16 Fixings	15
17 Sealing to Structural Opening	15
18 Insulation	17
19 Smoke Control	17
20 Conclusion	17
21 Declaration by the Applicant	18
22 Limitations	19
21 Validity	19
Appendix A Performance Data	20
Appendix B Assessed Glazing Systems	21
Appendix C Revisions and Amendments	23
Appendix D Data Sheets	24

The legal validity of this report can only be claimed on presentation of the complete report.

1 Introduction

This document constitutes a global assessment to collate the fire resistance test evidence for Pacific Rim Wood Ltd 'Flamebreak' 60 minute fire resisting doorsets, a construction manufactured by P.T. Kutai Timber of Indonesia. The assessment uses established extrapolation and interpretation techniques in order to extend the scope of application. It does this by determining the limits for the design, based on the tested constructions and performances obtained. The assessment is an evaluation of the potential fire resistance performance, if the elements were to be tested in accordance with BS 476: Part 22: 1987.

2 General Description of Construction

The construction of Flamebreak 60 door leaves includes the following basic components:

Component		Species/type	Configuration (all dimensions in mm)	Min. Density (kg/m ³)
Core - three layer	Outer layers	Parasorianthes falacateria or Albisia falcata	Vertically orientated 13.5 thick x 45 wide lamels	230-360
	Inner layer	'Mixed tropical hardwood'	Horizontally orientated 15 thick x 28 wide lamels	610
Stiles		Agathis or 'mixed tropical hardwood' – in 2 lamels	35 wide (total) x 42 thick with a 10 wide x 10 deep tongue into the core	Agathis - 480 or 'Mixed tropical hardwood' - 610
Top Rail		Agathis or 'mixed tropical hardwood' – in 3 lamels	100 wide (total) x 42 thick with an 10 wide x 10 deep tongue into the core	Agathis - 480 or 'Mixed tropical hardwood' - 610
Bottom Rail		Agathis or 'mixed tropical hardwood' – in 3 lamels	100 wide (total) x 42 thick with an 10 wide x 10 deep tongue into the core	Agathis - 480 or 'Mixed tropical hardwood' - 610
Facings		Hardwood plywood	6 thick	520 - 530
Lippings – all edges		Hardwood	10 thick	640

The Flamebreak 60 design is supplied with stiles and rails to the specification in the table above. The stiles and bottom rail may remain in position or be removed for manufacturing since the testing has evaluated constructions with and without these elements.

3 Leaf Sizes

It can be seen from the list of fire resistance tests contained in appendix A, that the most demanding configuration of the tested design is the unlatched, single acting, double leaf doorset and therefore extrapolation is based primarily upon this test. The assessment for increased leaf dimensions is based on the margin of over performance of the design above 60 minutes integrity, and the characteristics exhibited during test.

Doorsets containing leaves with smaller dimensions than those stated are deemed to be automatically covered.

4 Configurations

Based on the test evidence listed in appendix A, this assessment covers the following doorset configurations:

Abbreviation	Description
LSASD & ULSASD	Latched & unlatched single acting single doorset
DASD	Double acting single doorset
LSADD & ULSADD	Latched & unlatched single acting double doorset
DADD	Double acting double doorset

Unequal leaf double doorsets are covered by this assessment with no restriction on the smaller leaf dimension, providing the main leaf remains within the permitted size limits.

5 Leaf Size Adjustment

Door leaves to this design may be altered as follows:

Element	Reduction
Leaf	Leaves may be reduced in height and width without restriction, but reduction in height must be from the bottom edge only. The top rail must be preserved at its manufactured dimensions.
Timber lippings	The dimensions stated in section 9 may be reduced by 20% for fitting purposes.

6 Overpanels

Overpanels of the same construction as the door leaves may be used with this doorset design only when fitted with a transom. The transom must be of the same section and material assessed for the door frames and the overpanel must be fully contained within the door frame (see following diagram).

Door frame joints must utilise one of the following four methods: mortise and tenon joints; half lapped joints; mitre joints; butt joints (see section 10.2).

All methods require joints to be tight, with no gaps, and require mechanical fixing with the appropriate size ring shank nails or screws. Butt joints must be additionally bonded with urea formaldehyde or equivalent.

Overpanels must be fixed by screwing through the rear of the frame with steel screws passing at least 30mm into the centre line of the overpanel. Fixings must be no more than 100mm from each corner and a maximum of 250mm centres in between.

The intumescent seals specified for the jambs in appendix D, must also be fitted to all edges of the overpanel. The seals may be fitted in the overpanel edges or alternatively in the frame reveal. Maximum overpanel heights are as follows:

- Single doorsets - 2000mm
- Double doorsets - 1500mm.

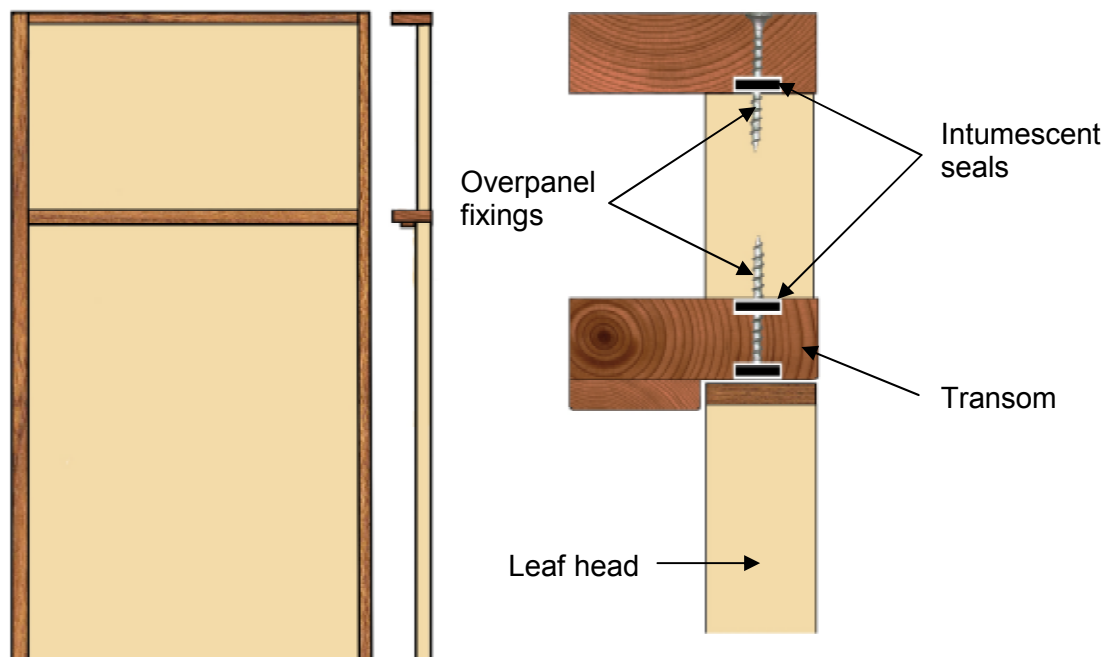

Note: Drawing is representative of doorset construction only, actual construction must be as the text within this document specifies.

7 Glazing

7.1 General

Test RF02055 has demonstrated that the design is capable of tolerating glazed apertures. The maximum permitted glazed area for all configurations is 0.72m² and the glazing must meet the following criteria:

7.2 Assessed Glazing Systems

The glazing system must be one of the following proprietary tested systems:

Product	Manufacturer
1. Therm-A-Glaze 60	Intumescent Seals Ltd
2. Fireglaze 60	Sealmaster Ltd
3. System 90+	Lorient Polyproducts Ltd
4. System 36/15	Lorient Polyproducts Ltd
5. System 63	Lorient Polyproducts Ltd (only suitable for circular apertures with glass types 1 & 2)
6. Pyroglaze 60	Mann McGowan Fabrications Ltd

7.3 Assessed Glass Products

Glass Type (Trade name)	Manufacturer
1. 7mm Pyroshield	Pilkington Group Ltd
2. 6mm Pyran S	Schott Glass Ltd
3. 6mm Pyrostem	CGI Ltd (limited to 0.6m ²)
4. 10mm Pyrodur	Pilkington Group Ltd
5. 12mm Pyrobelite	AGC Flat Glass Europe
6. 14mm Swissflam Lite	Vetrotech Saint Gobain Ltd
7. 15mm Pyrostop	Pilkington Group Ltd
8. 16mm Pyrobel	AGC Flat Glass Europe

All glass types must be fitted fully in accordance with the manufacturers' tested details/installation requirements, particularly with respect to edge cover and expansion tolerances.

7.4 Glazing Beads & Installation

Glazing beads must be from hardwood as specified in the following table:

Material	Profile	Density (kg/m ³)	Application
Hardwood	Splayed	≥ 640	All proprietary systems detailed in 7.2 and shown in appendix B and all glass types specified in 7.3
Hardwood	Square	≥ 640	Proprietary systems 1 & 2 as specified in 7.2 and glass types 6, 7 & 8 specified in 7.3

The legal validity of this report can only be claimed on presentation of the complete report.

Glazed openings must not be less than 100mm from any door edge. Multiple apertures are acceptable up to the maximum approved area, with a minimum dimension of 80mm between apertures. The aperture shape is not restricted, providing the intumescent material and beads are proven to be compatible with that shape.

A square bead profile may be used as an alternative to the splayed beads subject to the restricted glass types and glazing systems specified in the tables above. See appendix B for square bead options.

Glazing bead fixings must be retained in position with 60mm long x 2mm diameter steel pins or 60mm long No 6-8 screws, inserted at 35-40° to the vertical at no more than 50mm from each corner and at 150mm maximum centres. Pneumatically fired pins are acceptable providing they meet the specification given above.

False timber beads must not be applied across the glass face without specific test evidence to justify the system used.

Sectional drawings detailing the tested and approved proprietary glazing systems are contained in appendix B.

8 Facing Materials

8.1 Structural Facings

The following facing materials have been approved for use with the Flamebreak 60 design:

Material	Thickness (mm)	Min. Density (kg/m ³)	Maximum Leaf Size (mm)	Permitted Configurations
Hardwood Plywood	6	520 – 530	All	All
MDF	6	750	From: 2080(h) x 936(w) To: 2132(h) x 960(w)	LSASD & ULSASD & DASD

8.2 Decorative and Protective Facings

The following facing materials are permitted for this door design since they would degrade rapidly under test conditions without significant effect:

Facing Material	Maximum Permitted Thickness (mm)
Paint	0.5
Timber veneers	2
PVC/plastic laminates	2
Decorative paper / non-metallic foil	0.4

Notes:

1. Metallic facings are not permitted except for push plates and kick plates (see section 14.6)
2. The door leaf thickness may be reduced by a total maximum of 0.5mm for calibration purposes in order to accommodate the chosen finish
3. Materials must not conceal intumescent strips
4. PVC/plastic laminates must not be applied to leaf edges

9 Lippings

Doors require lipping on all edges and the vertical edge lippings must over-run the horizontal edge lippings. Lippings must meet the specification contained in the following table:

Material	Size (mm)	Min Density (kg/m ³)
Hardwood meeting or exceeding class J30 as specified in BS EN 942: 2007 (subject to adequate repair of any defects)	1. Flat = 10 – 15 thick with a maximum of 2mm profiling permitted at corners of lipping (see section 10.1)	640
	2. Rounded = 12 – 17 thick with a radius matching the distance between leaf edge and floor pivot (see section 10.1)	
	3. Rebated = Not assessed	

10 Door Frames

10.1 Door Frame Construction

Door frames for this design must meet the following specification:

Material	Section Size (mm)	Minimum Density (kg/m ³)
Hardwood	70 wide x 32 thick	≥ 640

All door frame timber must be to class J30 as specified in BS EN 942: 2007 (subject to adequate repair of any defects).

A 12mm deep planted stop is adequate for single acting frames. Frame joints may be mortice and tenoned, mitred, half lapped or butted and with no gaps (see section 10.2). All jointing methods require mechanical fixing with the appropriate size ring shank nails or screws.

Frames must be contained within and not offset in relation to the structural opening and must not be rebated adjacent to the door junction.

The following diagram depicts the assessed frame profiles and dimensions:

A = min 70mm
 R = radius from floor spring

B = min 32mm (see table above)
 8mm max radius to create a maximum 2mm edge profiling

C = min 12mm

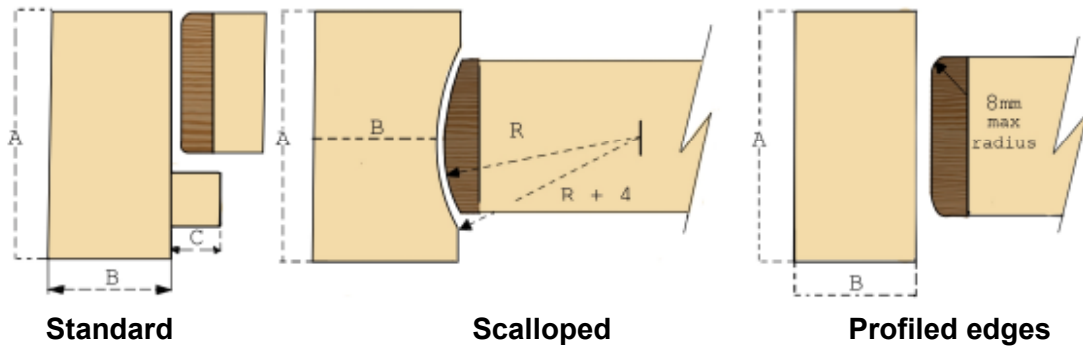

10.2 Door frame joints

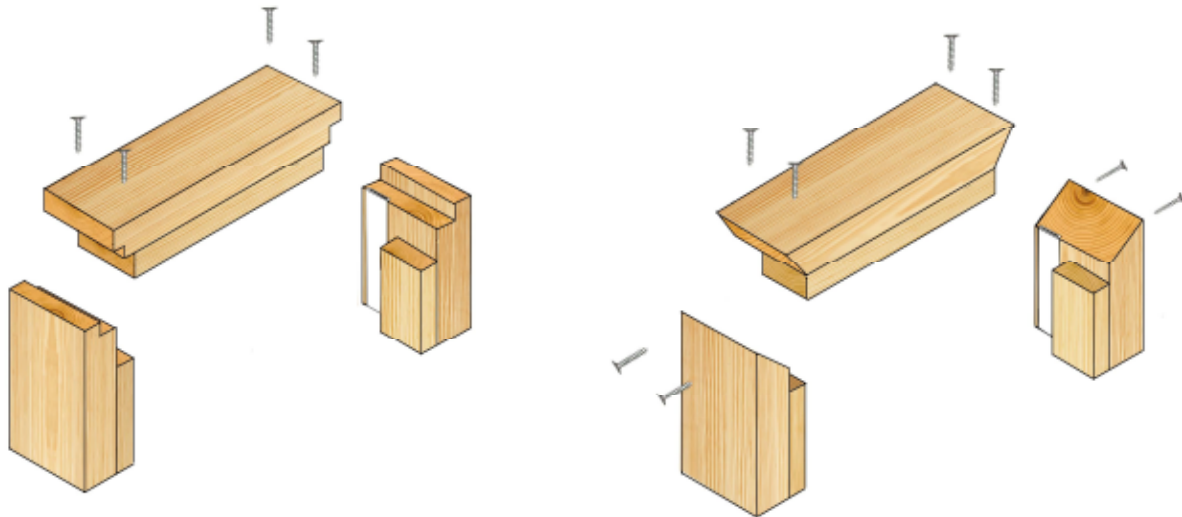

Half Lapped Joint

Mitre Joint

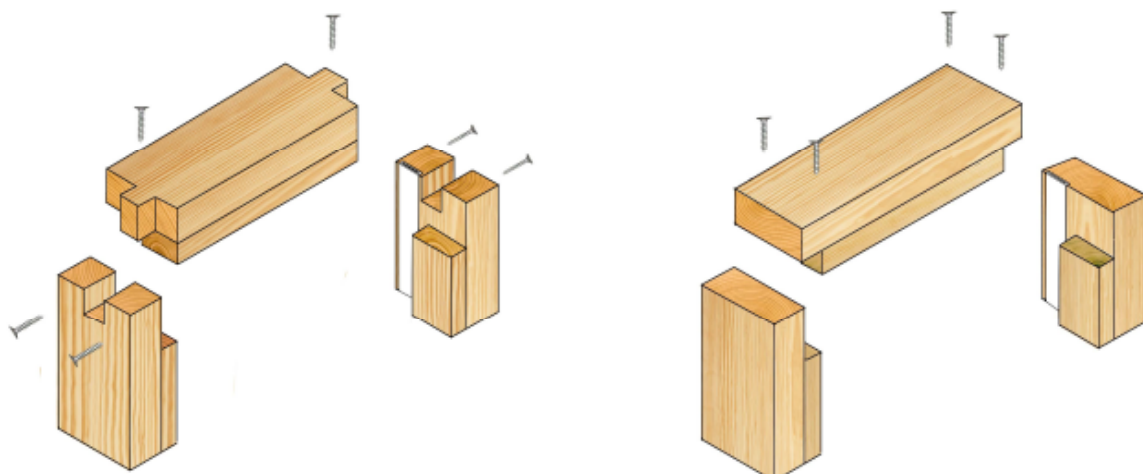

Mortice and Tenon Joint

Butt Joint

Note: Drawing is representative of doorset construction only, actual construction must be as the text within this document specifies.

The legal validity of this report can only be claimed on presentation of the complete report.

10.3 Door frame installation

The following diagrams indicate acceptable and unacceptable door frame installations:

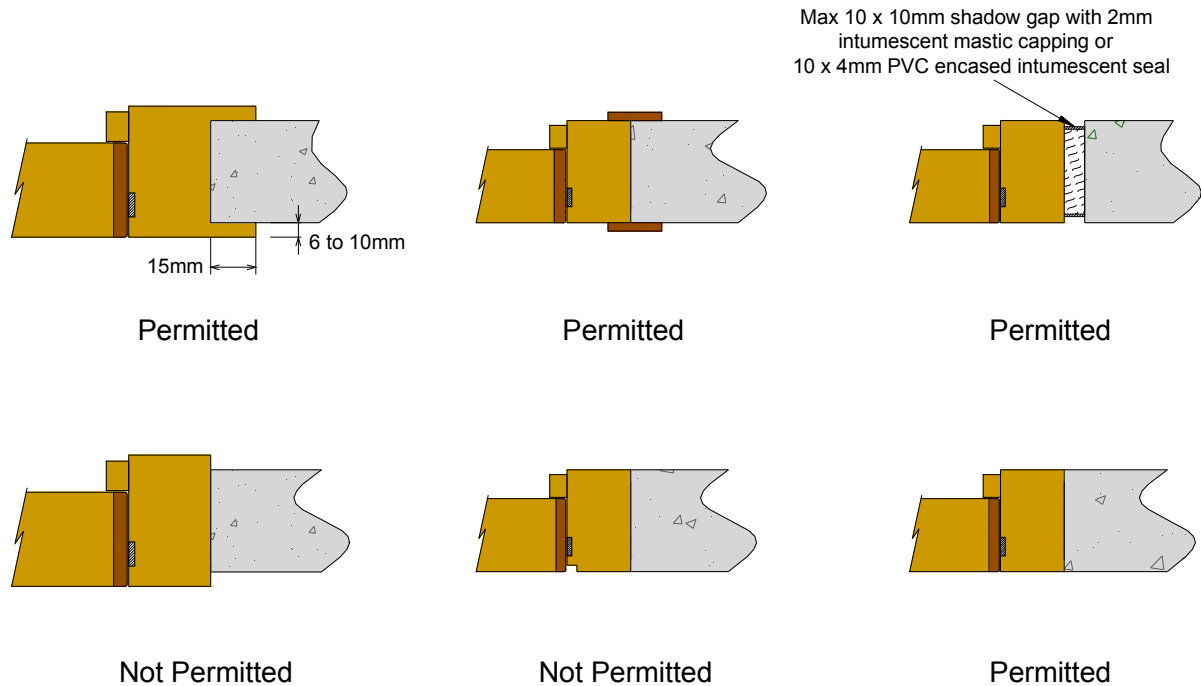

11 Intumescent materials

It is important that the type, size and fitting detail for the intumescent seals remains as tested. These products can often exhibit significantly different characteristics which could alter the performances obtained during test and therefore they must not be considered interchangeable, irrespective of whether the product has been tested and the seal dimensions are maintained.

The intumescent materials tested for this doorset design are as follows:

Element	Location	Product & Manufacturer
Edge seals	Fitted in the frame jambs or leaf edges	<ol style="list-style-type: none"> 1. PVC encapsulated Palusol 100 – Mann McGowan 2. Pyrostrip 500P – Mann McGowan 3. Type 617 - Lorient Polyproducts Ltd 4. Pyroplex Rigid Box Seal – Pyroplex
Hinges	Under both hinge blades	<ol style="list-style-type: none"> 1. 1mm Interdens – Dufaylite Developments Ltd 2. 1mm Therm-A-Strip – Intumescent Seals Ltd 3. 1mm G30 – Sealmaster Ltd
Locks and latches	Under forend & keep	<ol style="list-style-type: none"> 1. 1mm Interdens – Dufaylite Developments Ltd 2. 1mm Therm-A-Strip – Intumescent Seals Ltd 3. 1mm G30 – Sealmaster Ltd

The legal validity of this report can only be claimed on presentation of the complete report.

Element	Location	Product & Manufacturer
Top Pivots	Lining all sides of the mortices	<ol style="list-style-type: none"> 2mm Interdens – Dufaylite Developments Ltd 2mm Therm-A-Strip – Intumescent Seals Ltd 2mm G30 – Sealmaster Ltd
Flush bolts	Lining all sides of the mortices	<ol style="list-style-type: none"> 2mm Interdens – Dufaylite Developments Ltd 2mm Therm-A-Strip – Intumescent Seals Ltd 2mm G30 – Sealmaster Ltd

The required seal specification for each doorset configuration is contained in appendix D.

12 Adhesives

The following adhesives must be used in the construction of doorsets to this design:

Application	Product
Facings	Melamine
Core	PVA
Lippings	Urea or resorcinol formaldehyde. PU may only be used on single leaf doorsets – at all permitted leaf sizes

13 Tested Hardware

The following hardware has been successfully incorporated in the tests:

- Royde & Tucker H Load H101 steel butt hinges
- Dorma TS83V overhead closers
- Henderson Hardware 63mm tubular mortise latch with aluminium lever handles
- Euro Star 57mm tubular mortise latch with aluminium lever handles

14 Additional & Alternative Hardware

14.1 Latches & Locks

Latches and locks must either be as tested, or alternatively components with the following specification are acceptable:

Element	Dimensions (mm)
Maximum forend and strike plate dimensions:	235 high x 24 wide x 4 thick
Maximum body dimensions:	18 thick x 100 wide x 165 high.
Intumescent protection:	See section 11
Materials:	All parts essential to the locking/latching action, including the latch bolt, forend and strike are to be steel or stainless steel

The legal validity of this report can only be claimed on presentation of the complete report.

14.2 Hinges

Hinged doorsets must be hung on a minimum of 3 hinges, whilst leaves over 2300mm high must fit 4 hinges. Hinges with the following specification are acceptable:

Element	Dimensions (mm)	
Blade height:	90 – 120	
Blade width (excluding knuckle):	30 – 35	
Blade thickness:	2.5 - 4	
Fixings:	Minimum of 4 No. 30 long No. 8 or No.10 steel wood screws per blade	
Materials:	Steel or stainless steel	
Hinge positions (to top of blade):	Top:	150 – 200 from the head to top of hinge
	Bottom	150 – 250mm from the foot of leaf to bottom of hinge
	Remainder	Equispaced between top and bottom hinges
Intumescent protection:	See section 11	

14.3 Automatic Closing

Automatic closing devices, must either be as tested or components of equal specification that have demonstrated contribution to the required performance of this type of 60 minute doorset design, when tested to BS 476: Part 22: 1987 or BS EN 1634-1: 2000.

Note: The top pivots to floor spring assemblies must be protected with 2mm thick intumescent gasket as specified in section 11 and 5mm of head seal must remain continuous past each side of the mortice

14.4 Flush Bolts

Flush bolts may be incorporated into the top and bottom of the meeting edge of the inactive leaf of a double doorset, provided that the following maximum dimensions are not exceeded and square edge lippings are used:

- 200mm long x 20mm deep x 20mm wide.

The mechanisms of the flush bolts must be of steel and the mortice must be lined on all edges with 2mm thick intumescent gasket as specified in section 11. Alternatively the hardware manufacturers tested gaskets may be used.

The mortice must be as tight to the mechanism as is compatible with its operation. The mechanism of the flush bolt must be located opposite the intumescent seals specified for the meeting edge of a double doorsets as specified in appendix D.

The following diagram depicts the location of the required intumescent gaskets

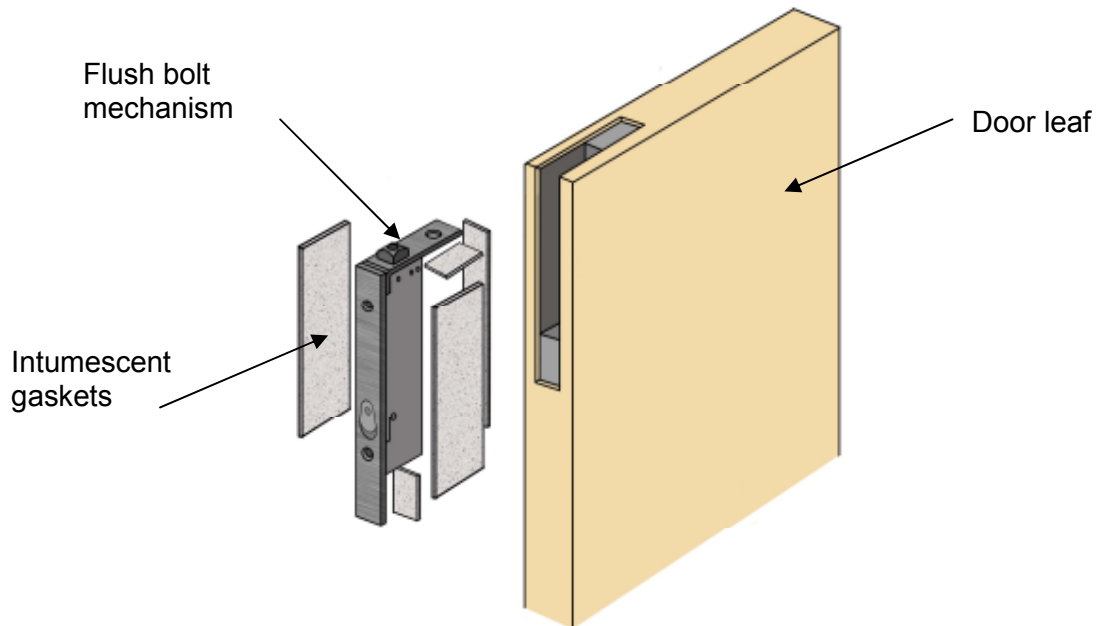

14.5 Pull Handles

These may be surface-fixed to the door leaf provided that they are steel or brass, and that their length is limited to 1200mm between the fixing points. No additional intumescent protection is required provided that the hole for the bolt through the leaf is tight.

14.6 Push Plates/Kick Plates

Face-fixed hardware such as push plates and kick plates may be fitted to the doorsets provided that their fitting requires the removal of no part of the door leaf. These items of hardware are permitted up to a maximum of 20% of the door leaf area if mechanically fixed and a maximum of 30% if bonded with a contact or other thermally softening adhesive. Plates must not return around the door edges.

14.7 Door Selectors

Selectors may be fitted providing the installation does not require the removal of any timber from the leaf, stop or frame reveal and they do not interfere with the self-closing action of the door leaf.

14.8 Letter Boxes/Plates

Letter boxes/plates may be fitted providing the product has demonstrated a contribution to the required performance of this type of 60 minute doorset design, when installed within a timber based doorset of comparable thickness and tested to BS 476: Part 22: 1987 or BS EN 1634-1: 2000. Margins to the leaf edges must remain as detailed for glazing. The position of the letter box/plate will be dictated by the pressure regime tested in the proving evidence (normally below mid height).

The legal validity of this report can only be claimed on presentation of the complete report.

14.9 Door Security Viewers

Door security viewers with brass or steel bodies of a diameter less than or equal to 15mm may be used provided that the through-hole is bored tight to the case of the viewer (maximum tolerance +1 mm). Lenses must be glass and the item must be bedded in to a tested intumescent mastic.

14.10 Air Transfer Grilles

Air transfer grilles may be fitted providing the product has suitable test evidence to BS 476: Part 22: 1987 or BS EN 1634-1: 2000 that demonstrates a minimum 60 minutes integrity performance when installed within a timber based doorset of comparable thickness. Margins to the leaf edges will remain as detailed for glazing and the position of the unit will be dictated by the pressure regime tested in the proving evidence (normally below mid height). The area occupied by the air transfer grille must not exceed 0.1m².

14.11 Acoustic, Weather and Dust Seals

Silicon based acoustic, weather and dust seals may be fitted to this doorset design without compromising the performance, providing their fitting does not interfere with the activation of the intumescent seals or hinder the self closing function of the leaves.

14.12 Threshold Seals

The following types of automatic threshold drop seals may be recessed in to the bottom rail of leaves to this design with out compromising the performance:

Manufacturer	Product
Lorient Polyproducts	IS8005si and IS8010si
Pemko	411-AR, 411-RL & 411-NBL
Raven	RP8 and RP78
Domatic	A6003

Alternative products may be used providing they are essentially of the same construction, materials and dimensions.

15 Door Gaps

Door edge gaps and alignment tolerances must fall within the following range:

Location	Dimension
Door edge gaps	A minimum of 2mm and a maximum of 4mm.
Alignment tolerances	Leaves must not be proud of each other or from the door frame by more than 1mm.
Threshold gap	A maximum of 10mm between bottom of leaf and top of floor covering.

16 Structural Opening

The supporting construction must provide the required level of fire resistance designated for the doorset design and be a suitable medium to permit adequate fixity.

17 Fixings

The frame jambs are to be fixed to the supporting construction using steel fixings at 600mm maximum centres. The fixings must be of the appropriate type for the supporting construction and must penetrate to a minimum depth of 40mm. It is not necessary to fix the frame head, although packers must be inserted.

18 Sealing to Structural Opening

The door frame to structural opening gap must be protected using one of the following methods:

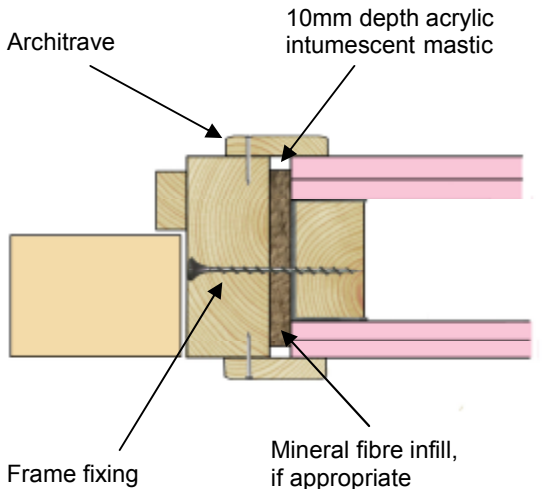
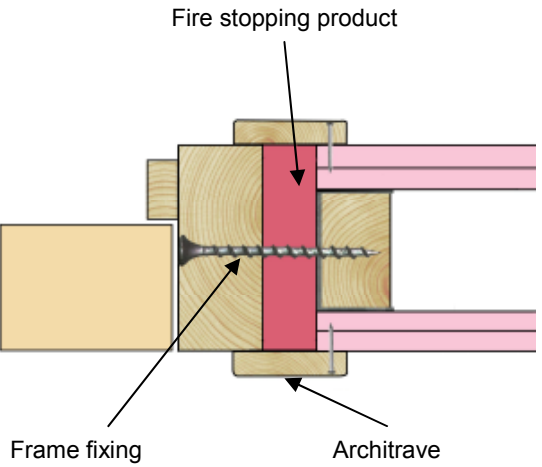
1)	Gaps up to 10mm must be sealed on both sides with a 10mm depth of acrylic intumescent mastic, fire tested for this application to BS 476: Part 22: 1987 or BS EN 1634-1: 2000.	
2)	Gaps between 10mm and 20mm must be tightly packed with mineral fibre capped on both sides with a 10mm depth of acrylic intumescent mastic, fire tested for this application to BS 476: Part 22: 1987 or BS EN 1634-1: 2000.	
3)	Gaps up to 20mm must be filled with proprietary fire stopping product (e.g. expanding PU foam or preformed compressible intumescent foam). Products must be tested for this application to BS 476: Part 22: 1987 or BS EN 1634-1: 2000.	

The legal validity of this report can only be claimed on presentation of the complete report.

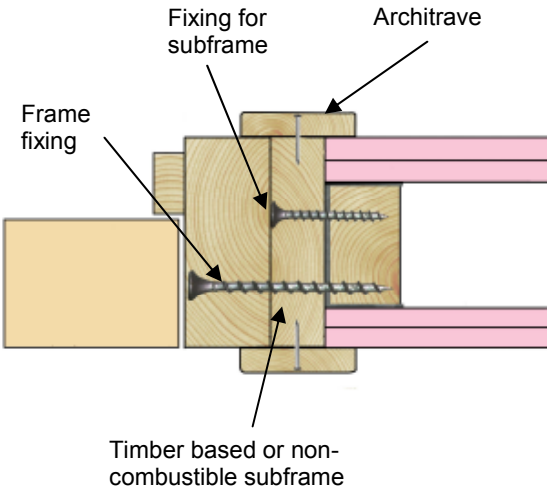
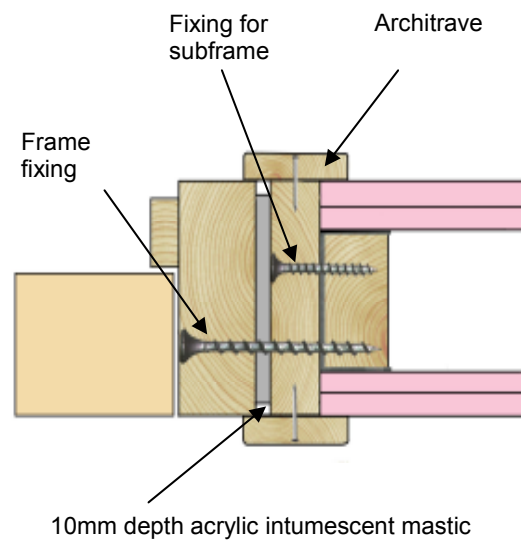
<p>4)</p>	<p>Gaps up to 40mm must be filled with full depth timber or timber based composite subframe up to 40mm thick, with no gaps between the components and fitted with a minimum of 10mm thick architraves</p>	
<p>5)</p>	<p>Gaps greater than 20mm require a full depth timber or timber based composite material or non-combustible subframe. Gaps up to 10mm between components must be sealed on both sides with a 10mm depth of appropriately fire tested acrylic intumescent mastic or full depth expanding PU foam. Gaps between 10mm and 20mm must be fire stopped as described in either point 2 or 3 above. Products must be tested for this application to BS 476: Part 22: 1987 or BS EN 1634-1: 2000.</p>	

Guidance for various methods of sealing the frame to structural opening gap is also given in BS 8214: 2008, Code of practice for timber fire doors, which may be referred to where appropriate.

Note: Drawings are representative of doorset installation only, actual installations must be as the text within this document specifies

19 Insulation

Insulation performance may be claimed for a doorset to this design meeting the following:

Type	Details
Partially insulating	Doorsets incorporating up to 20% of non-insulating glazing
Fully insulating	Unglazed doorsets

20 Smoke Control

If the doorset design is required to provide a smoke control function to comply with Building Regulations, it must be fitted with a smoke seal or combined intumescent/smoke seal, that has been tested in accordance with BS 476: Part 31: Section 31.1 and demonstrated to maintain the leakage rate below 3m³/m/h when tested at 25Pa.

Providing the smoke seals, any interruptions, door gaps, type/configuration of door is consistent with the tested detail, the doorset will comply with current smoke control legislation and a suffix 'S' may be added to the designation. Any other installed components where smoke leakage may occur must also be taken into account.

Note: The incorrect specification and fitting of smoke seals may impair the operation of a doorset and therefore compromise the fire resistance performance.

21 Conclusion

If Flamebreak 60 doorsets, constructed in accordance with the specification documented in this global assessment, were to be tested in accordance with BS 476 : Part 22 : 1987, it is our opinion that they would provide a minimum of 60 minutes integrity and insulation (subject to section 19).

22 Declaration by the Applicant

1. We the undersigned confirm that we have read and comply with obligations placed on us by FTSG Resolution No 82: 2001.
2. We confirm that the component or element of structure, which is the subject of this assessment, has not to our knowledge been subjected to a fire test to the Standard against which this assessment is being made.
3. We agree to withdraw this assessment from circulation should the component or element of structure be the subject of a fire test to the Standard against which this assessment is being made.
4. We are not aware of any information that could adversely affect the conclusions of this assessment.
5. If we subsequently become aware of any such information we agree to ask the assessing authority to withdraw the assessment.

Signed:



Name:

SHAUN HANNAN
LIMITED

For and on behalf of Pacific Rim Wood Ltd

The legal validity of this report can only be claimed on presentation of the complete report.

23 Limitations

The following limitations apply to this assessment:

1. This assessment addresses itself solely to the elements and subjects discussed and does not cover any other criteria. All other details not specifically referred to should remain as tested or assessed.
2. This assessment is issued on the basis of test data and information to hand at the time of issue. If contradictory evidence becomes available, CIF reserves the right to withdraw the assessment unconditionally but not retrospectively.
3. This assessment has been carried out in accordance with Fire Test Study Group Resolution No 82: 2001.
4. Opinions and interpretations expressed herein are outside the scope of UKAS accreditation.
5. This assessment relates only to those aspects of design, materials and construction that influence the performance of the element(s) under fire resistance test conditions. It does not purport to be a complete specification ensuring fitness for purpose and long-term serviceability. It is the responsibility of the client to ensure that the element conforms to recognised good practice in all other respects and that, with the incorporation of the guidance given in this assessment, the element is suitable for its intended purpose.

24 Validity

1. The assessment is valid initially for a period of two years and one month after which time it must be submitted to CIFL for technical review.
2. This assessment report is not valid unless it incorporates the declaration given in Section 22 duly signed by the applicant.

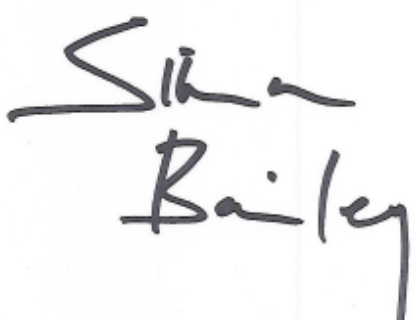
Signatures:		
Name:	P N Barker	S Bailey
Title:	Senior Consultant	Product Assessor

The legal validity of this report can only be claimed on presentation of the complete report.

Appendix A Performance Data

Primary Data

Test Reference	Configuration	Leaf Size (mm)	Test Standard	Integrity (mins)
RF02054 (Palusol)	2 No. ULSASD	A = 2070 x 935 x 54 B = 2062 x 935 x 54	BS 476: Part 22:1987	A = 54* B = 58*
RF02055 (Pyrostrip 500P)	ULSADD	2155 x 935/845 x 54	BS 476: Part 22:1987	60
RF02117 (Pyrostrip 500P)	2 No. ULSASD	A = 2080 x 937 x 54 B = 2380 x 1179 x 54	BS 476: Part 22:1987	A = 71 B = 61
RF05042 (MDF faces)	A: ULSASD	2080 x 936 x 54	BS 476: Part 22: 1987	A = 63
RF08117 (PU lipping glueline and Pyroplex seals)	B: ULSASD	2040 x 826 x 54	BS 476: Part 22: 1987	B= 62

ULSASD – Unlatched, Single Acting, Single Doorset
 ULSADD – Unlatched, Single Acting, Double Doorset

* The failed single leaf, single acting doorset designs have been assessed through a change in intumescent specification.

Supplementary test evidence

Assessment Reference	Configuration	Leaf Size (mm)	Test Standard	Integrity (mins)
Chilt/A07051 Rev B** (assessment of Lorient 617 seals)	Single and double doorsets	Various	BS 476: Part 22: 1987	60
Warres 191350 (Pyrostem)	Fixed sample	1495 926 54	Principles of BS 476: Part 20: 1987	62

** Details of the supplementary test evidence are contained within this assessment report.

The legal validity of this report can only be claimed on presentation of the complete report.

Appendix B

Assessed 60 Minute Glazing Systems

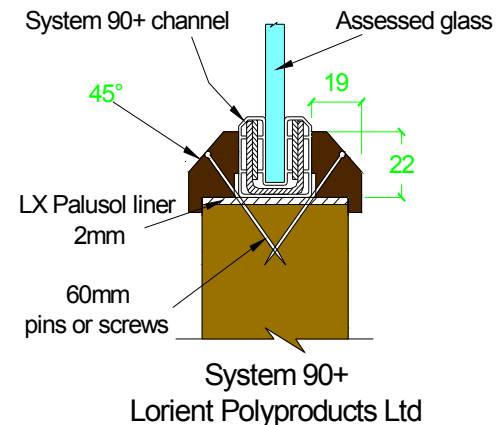
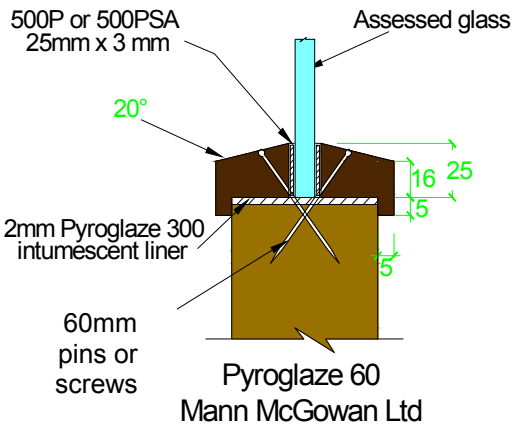
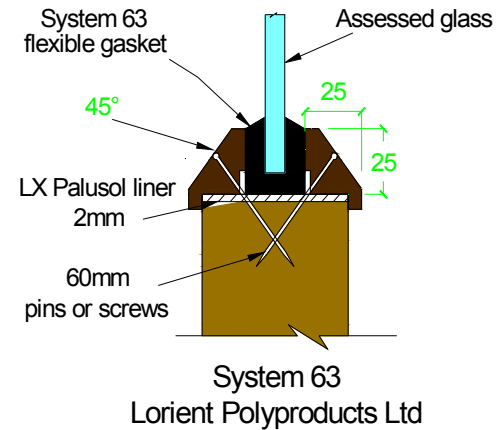
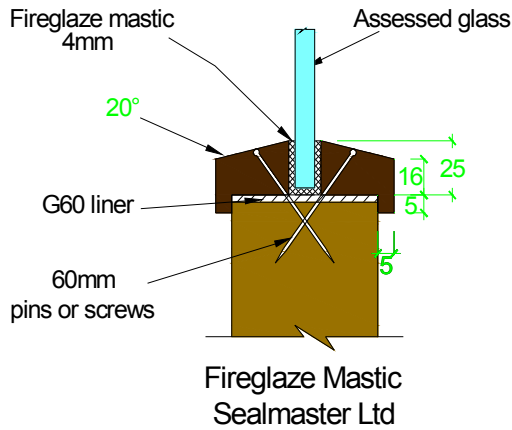
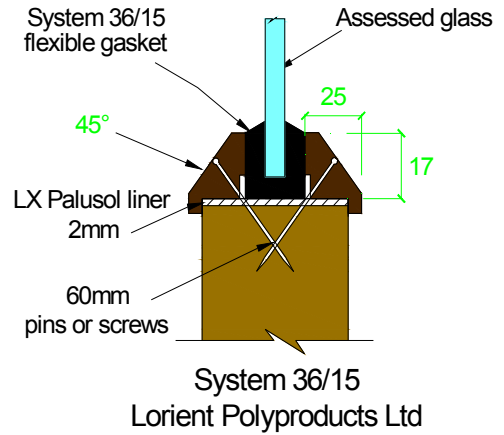
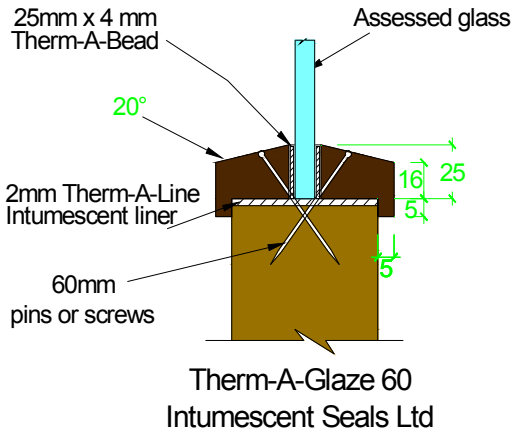

The legal validity of this report can only be claimed on presentation of the complete report.

Assessed Square Glazing Bead Profiles

The following square bead profiled may be used as an alternative to the splayed beads detailed above - refer to section 7 for glazing system and glass restrictions.

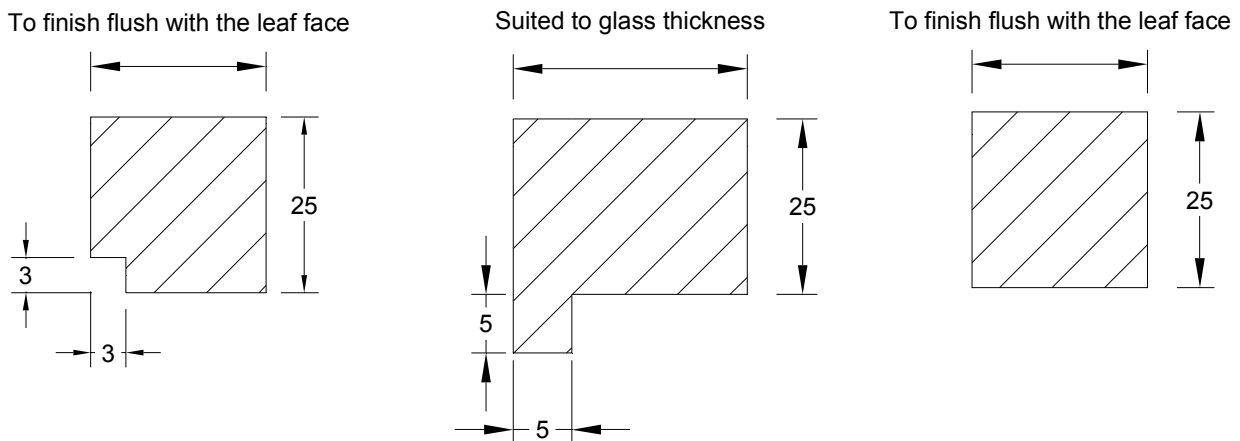

The legal validity of this report can only be claimed on presentation of the complete report.

Appendix C

Revisions & Amendments

Revision	CIFL Reference	Date	Description
A	FEA/F02141	05.03.03	Incorporation of additional test evidence Ref: RF02117 and RF02118 to include mixed hardwood stiles and rails and increase the leaf sizes in Appendix D. Inclusion of MDF facings on LSASD. Filed under FEA/F03047.
B	FEA/F03047A	01.02.06	Change of top rail dimension to 100mm. Files under FEA/F03047 Revision A.
C	FEA/F07039	21.06.07	Update and revalidated for a further five year period. Issued under reference FEA/F07039.
D	FEA/F07171	22.08.07	Inclusion of Lorient Type 617 seals and revalidation for 5 years.
E	FEA/F09153	15.07.10	Update and revalidate assessment, including PU glue lines for lippings and Pyroplex seals for single leaf doors.
F	FEA/F09153 rev F	22.07.10	Edit to intumescent gaskets required for flush bolts and top pivots

The legal validity of this report can only be claimed on presentation of the complete report.

Appendix D

**Data Sheets for
Pacific Rim Wood Ltd
'Flamebreak' Doorsets
FD60 Performance**

The legal validity of this report can only be claimed on presentation of the complete report.

Pacific Rim Wood Ltd – Flamebreak 60 Doorsets

Latched and Unlatched Single & Double Acting Single Doorsets – Palusol & Type 617

Leaf Sizes	Configuration		Height (mm)		Width (mm)
	LSASD	From:		2062	x
To:			2112	x	935
ULSASD & DASD	From:		2062	x	935
	To:		2062	x	935
Maximum Overpanel height (mm)	Transomed		2000		
Glazing	Maximum Glazed Area:		0.72m ²		
	Approved systems:		See section 7 and appendix B		
Frame specification	Min. Section (mm):		70 x 32		
	Material:		Hardwood		
	Density (kg/m ³):		640		
Intumescent Materials: Lorient Polyproducts Ltd – Type 617 or PVC encased Palusol Head: 1 No 30 x 4mm fitted centrally in the frame reveal. Jamb: 2 No 15 x 4mm fitted centrally 10mm apart in the frame reveal. Hardware Protection: see section 11					

Maximum Door Leaf Size

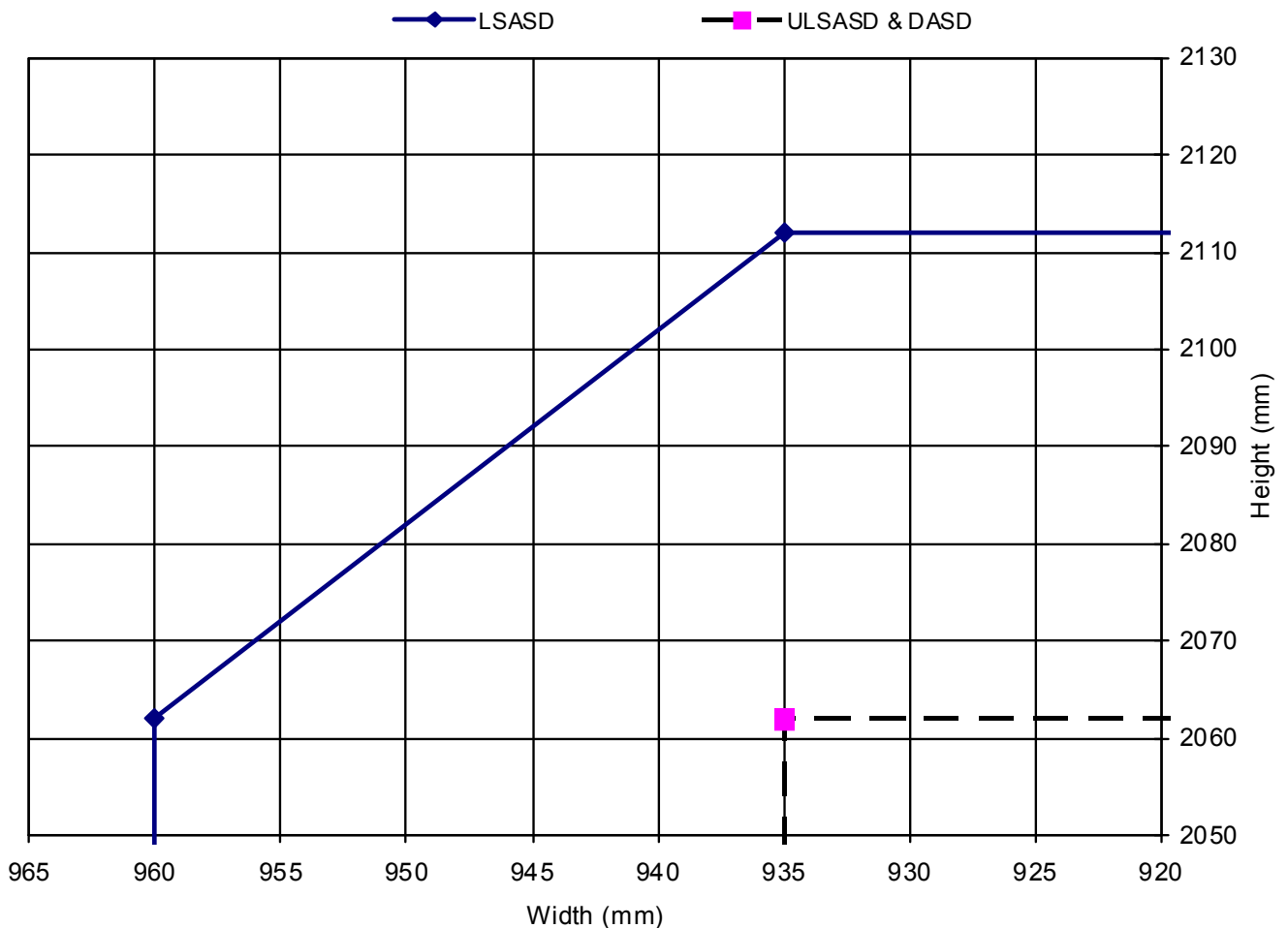

The legal validity of this report can only be claimed on presentation of the complete report.

Pacific Rim Wood Ltd – Flamebreak 60 Doorsets

Latched and Unlatched Single & Double Acting Single Doorsets – Pyrostrip

Leaf Sizes	Configuration		Height (mm)		Width (mm)
	LSASD	From:		2155	x
To:			2305	x	935
ULSASD & DASD	From:		2155	x	985
	To:		2255	x	935
Maximum Overpanel height (mm)	Transomed		2000		
Glazing	Maximum Glazed Area:		0.72m ²		
	Approved systems:		See section 7 and appendix B		
Frame specification	Min. Section (mm):		70 x 32		
	Material:		Hardwood		
	Density (kg/m ³):		640		
Intumescent Materials: Mann McGowan Fabrications Ltd – Pyrostrip 500P Head: 1 No 30 x 4mm fitted centrally in the frame reveal. Jamb: 2 No 15 x 4mm fitted centrally 10mm apart in the frame reveal. Hardware Protection: see section 11					

Maximum Door Leaf Size

—■— LSASD —◆— ULSASD & DASD

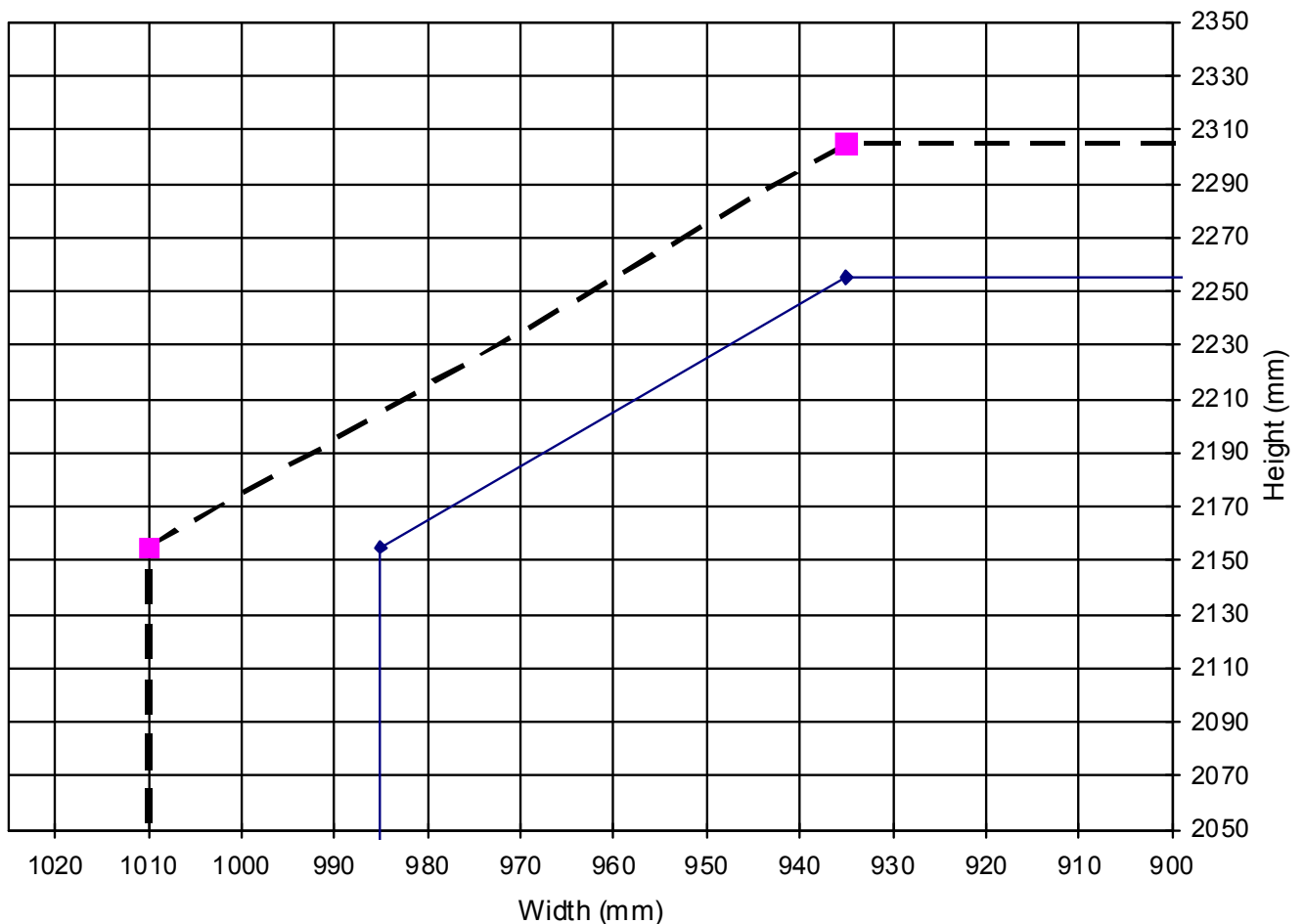

The legal validity of this report can only be claimed on presentation of the complete report.

Pacific Rim Wood Ltd – Flamebreak 60 Doorsets

Latched and Unlatched Single & Double Acting Single Doorsets - Pyroplex

Leaf Sizes	Configuration		Height (mm)		Width (mm)
	LSASD	From:		2040	x
To:			2124	x	826
ULSASD & DASD	From:		2040	x	840
	To:		2074	x	826
Maximum Overpanel height (mm)	Transomed		2000		
Glazing	Maximum Glazed Area:		0.72m ²		
	Approved systems:		See section 7 and appendix B		
Frame specification	Min. Section (mm):		70 x 32		
	Material:		Hardwood		
	Density (kg/m ³):		640		
Intumescent Materials: Pyroplex – PVC encased Rigid Box Seal Head: 2 No 15 x 4mm fitted centrally 10mm apart in the frame reveal. Jamb: 2 No 15 x 4mm fitted centrally 10mm apart in the frame reveal. Hardware Protection: see section 11					

Maximum Door Leaf Size

■ LSASD ◆ ULSASD & DASD

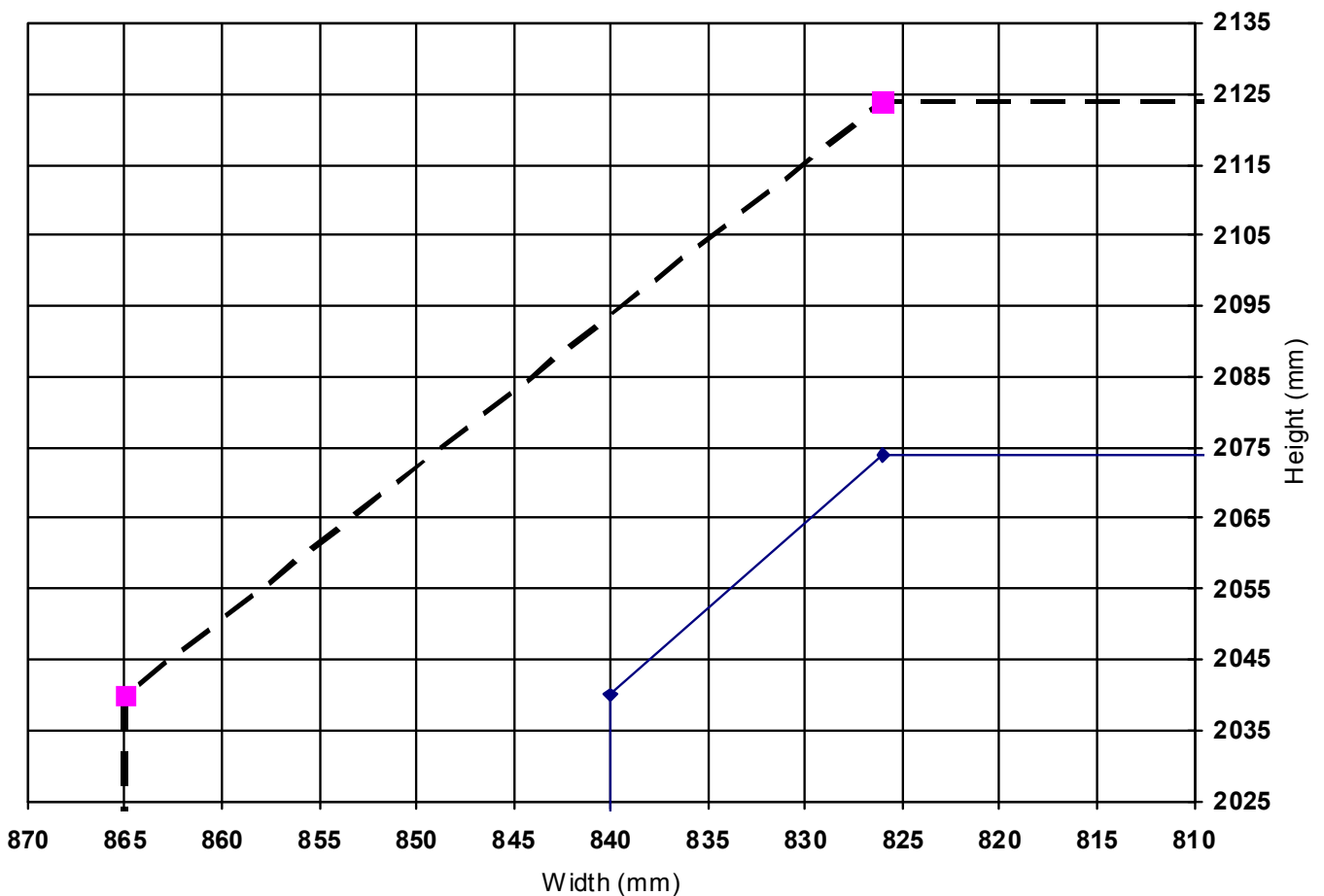

The legal validity of this report can only be claimed on presentation of the complete report.

Pacific Rim Wood Ltd – Flamebreak 60 Doorsets

Latched and Unlatched Single & Double Acting Single Doorsets – Large Leaf - Pyrostrip

Leaf Sizes	Configuration		Height (mm)		Width (mm)
	LSASD	From:	2380	x	1213
		To:	2450	x	1179
ULSASD & DASD	From:	2380	x	1188	
	To:	2400	x	1179	
Maximum Overpanel height (mm)	Transomed	2000			
Glazing	Maximum Glazed Area:	0.72m ²			
	Approved systems:	See section 7 and appendix B			
Frame specification	Min. Section (mm):	70 x 32			
	Material:	Hardwood			
	Density (kg/m ³):	640			
Intumescent Materials: Pyroplex - Pyrostrip 500P Head: 2 No 15 x 4mm fitted centrally 10mm apart in the frame reveal. Jamb: 2 No 15 x 4mm fitted centrally 10mm apart in the frame reveal. Hardware Protection: see section 11					

Maximum Door Leaf Size

—■— LSASD —◆— ULSASD & DASD

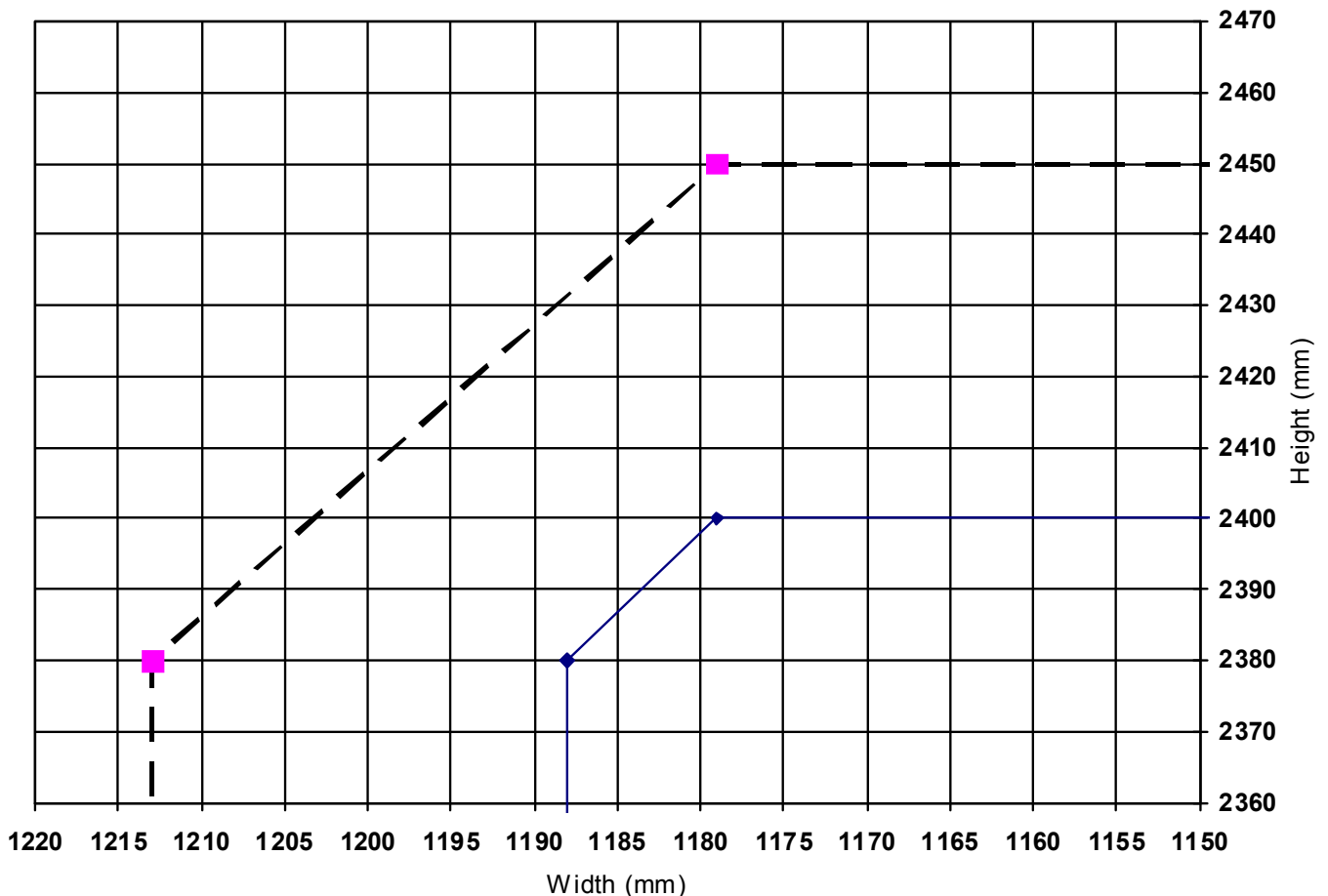

The legal validity of this report can only be claimed on presentation of the complete report.

Pacific Rim Wood Ltd – Flamebreak 60 Doorsets

Latched and Unlatched Single & Double Acting Double Doorsets – Pyrostrip

Leaf Sizes	Configuration		Height (mm)	Width (mm)
	LSADD	From:		2155
To:			2205	x 935
ULSADD & DADD	From:		2155	x 935
	To:		2155	x 935
Maximum Overpanel height (mm)		Transomed	1500	
Glazing	Maximum Glazed Area:		0.72m ²	
	Approved systems:		See section 7 and appendix B	
Frame specification	Min. Section (mm):		70 x 32	
	Material:		Hardwood	
	Density (kg/m ³):		640	
Intumescent Materials: Mann McGowan Fabrications Ltd – Pyrostrip 500P Head: 1 No 30 x 4mm fitted centrally in the frame reveal. Jamb: 2 No 15 x 4mm fitted centrally 10mm apart in the frame reveal. Meeting Edges: 2 No 15 x 4mm fitted centrally 8mm apart in one leaf edge. Hardware Protection: see section 11				

Maximum Door Leaf Size

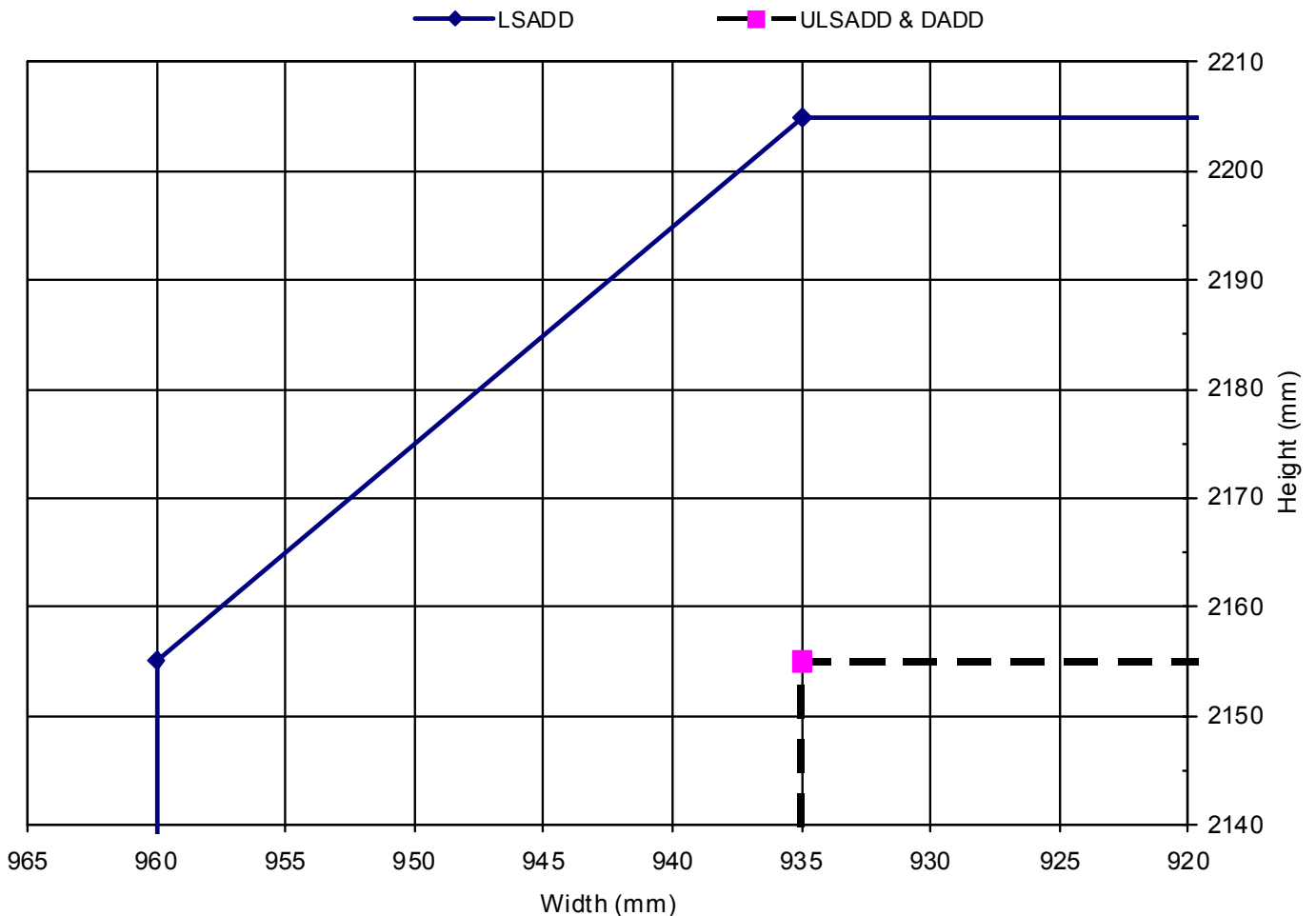

The legal validity of this report can only be claimed on presentation of the complete report.