

Global Assessment of:

Pacific Rim Wood Ltd

FLAMEBREAK

30 Minute Fire Resisting Doorsets

Report No: FEA/F98164 Revision I

**Valid From: 19 July 2010
Valid Until: 22 September 2012**



committed to excellence

www.chilternfire.co.uk

www.chilterndynamics.co.uk

www.qmark.info

Prepared for:

**Pacific Rim Wood Ltd
Unit 3, Kingdom Fields
Bratton Fleming
Barnstaple
EX31 4EN**

This document is confidential and remains the property of Chiltern International Fire Ltd. The legal validity of this report can only be claimed on the presentation of the complete report.

Contents

	Page No
1 Introduction.....	3
2 General Description of Construction	3
3 Leaf Sizes.....	4
4 Configurations	4
5 Leaf Size Adjustment.....	4
6 Overpanels	5
7 Glazing	6
8 Door Frames	9
9 Edging Materials.....	11
10 Leaf Facing Materials	12
11 Intumescent Materials	13
12 Adhesives.....	14
13 Tested Hardware	14
14 Additional & Alternative Hardware	14
15 Door Gaps.....	18
16 Fixings.....	18
17 Classification of Timber	18
18 Sealing to Structural Opening	19
19 Insulation.....	20
20 Smoke Control.....	21
21 Conclusion.....	21
22 Declaration by the Applicant	22
23 Limitations	23
24 Validity.....	23
Appendix A - Performance data	24
Appendix B - Glazing systems	26
Appendix C - Revisions.....	28
Appendix D - Data sheets	29

The legal validity of this report can only be claimed on presentation of the complete report.

1 Introduction

This document constitutes a global assessment to collate the fire resistance test evidence for Pacific Rim Wood Ltd 'Flamebreak' 30 minute fire resisting doorsets, a construction manufactured by P.T. Kutai Timber of Indonesia. The assessment uses established extrapolation and interpretation techniques in order to extend the scope of application. It does this by determining the limits for the design, based on the tested constructions and performances obtained. The assessment is an evaluation of the potential fire resistance performance, if the elements were to be tested in accordance with BS 476: Part 22: 1987.

2 General Description of Construction

The construction of 'Flamebreak' 30 minute door leaves includes the following basic components in the design:

Component	Species/type	Configuration (all dimensions in mm)	Min. density (kg/m ³)
Core	Parasoriantes falacateria or Albisia falcata	3 layers of lamels laid in alternate directions – grooved to accept the stiles and rails.	230-360
Stiles	'Mixed tropical hardwood'	1 No 26-36 thick (depending on facing thickness) x 35 deep, incorporating a 9 x 9 tongue to locate into the core material.	610
Top & Bottom Rails	'Mixed tropical hardwood'	1 No 26-36 thick (depending on facing thickness) x 35 deep, incorporating a 9 x 9 tongue to locate into the core material.	610
Top Rail (For leaves >2135 x 915mm)	'Mixed tropical hardwood'	1 No 26-36 thick (depending on facing thickness) x 70 deep, incorporating a 9 x 9 tongue to locate into the core material.	
Facings	Various timber based products – see section 10 for details.	Between 3.6 – 9mm – see section 10 for details.	various
Lippings	Hardwood	6 mm to 18 mm	640

The 'Flamebreak' design is supplied with stiles and rails to the specification in the table above. The stiles and bottom rail may remain in position or be removed for manufacturing since the testing has evaluated constructions with and without these elements.

Note: Care must be taken to observe the restrictions that apply to the 'Flamebreak' 30 design depending on the type and thickness of the facing material used. The restrictions are referenced in the data sheets in appendix D.

3 Leaf Sizes

The approval for increased leaf dimensions is based on the tests listed in appendix A and takes into account the margin of over performance above 30 minutes integrity for the design and the characteristics exhibited during test. Data sheets specifying the maximum approved leaf sizes and graphs showing the permitted gradient between maximum height and width are contained in appendix D.

Doorsets with reduced dimensions are deemed to be less onerous. Therefore, doors with dimensions that are less than those tested and stated in appendix D, may be manufactured.

4 Configurations

Based on the test evidence listed in appendix A, this assessment covers the following doorset configurations:

Abbreviation	Description
LSASD & ULSASD	Latched & unlatched single acting single doorset
DASD	Double acting single doorset
LSASD+OP & ULSASD+OP	Latched & unlatched single acting single doorset with overpanel
DASD+OP	Double acting single doorset with overpanel
LSADD & ULSADD	Latched & unlatched single acting double doorset
DADD	Double acting double doorset
LSADD+OP & ULSADD+OP	Latched & unlatched single acting double doorset with overpanel
DADD+OP	Double acting double doorset with overpanel

Unequal leaf double doorsets are covered by this assessment with no restriction on the smaller leaf dimension.

5 Leaf Size Adjustment

'Flamebreak' 30 door leaves may be altered as follows:

Element	Reduction
Leaf	Door leaves of this design have been tested in single and double leaf configuration both with and without stiles and bottom rails. This therefore permits the door leaves to be reduced in height and / or width without restriction, providing that reduction in height is made from the bottom edge only and the top rail remains unaltered.
Lipping	The dimensions stated in section 9 may be reduced by 20% for fitting purposes.

6 Overpanels

6.1 Solid

Overpanels of the same construction as the door leaves may be used either flush with the leaf heads or when separated by a transom. In either case the overpanel must be fully contained within the door frame (see following diagram). The following parameters apply:

- All 'Flamebreak' 30 designs may be used in conjunction with an overpanel fitted with a transom.
- It is only permitted to use a flush overpanel with the 'Flamebreak' 30 design when the door sections are faced with 4mm Plywood.

If a transom is used it must be to the same specification as the timber door frame (see section 8). Door frame joints must utilise one of the following four methods: mortise and tenon joints; half lapped joints; mitre joints; butt joints (see section 8.2).

All methods require joints to be tight, with no gaps, and require mechanical fixing with the appropriate size ring shank nails or screws. Butt joints must be additionally bonded with urea formaldehyde or equivalent.

Overpanels must be fixed by the following method:

- Steel screws inserted through the rear of the door frame, passing at least 30mm into the centre line of the overpanel. Fixings must be no more than 100mm from each corner and a maximum of 250mm centres in between.

Maximum overpanel heights are as follows.

- Single doorsets - 2000mm
- Double doorsets - 1500mm

The intumescent seals specified for the jambs in appendix D, must also be fitted to all edges of the overpanel. The seals may be fitted in the overpanel edges or alternatively in the frame reveal.

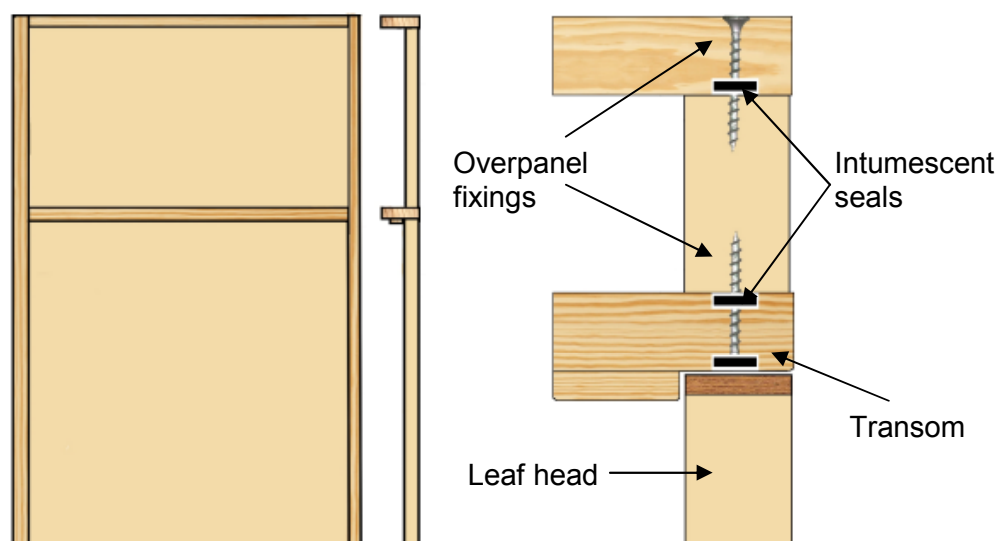

Note: Drawing is representative of doorset construction only, actual construction must be as the text within this document specifies.

6.2 Glazed Fanlights

Timber frame doorsets including a transom may have the overpanel section glazed in lieu of a section of door. The glazing system and glass must be able to demonstrate adequate performance when tested as a window or screen in accordance with BS476: Part 22: 1987 or BSEN 1634-1: 2000. The timber frame and glazing beads must be hardwood with a minimum density of 640 kg/m³ and the frame section must be a minimum of 70mm x 44mm.

MDF and softwood frame doorsets are not assessed for glazed fanlights.

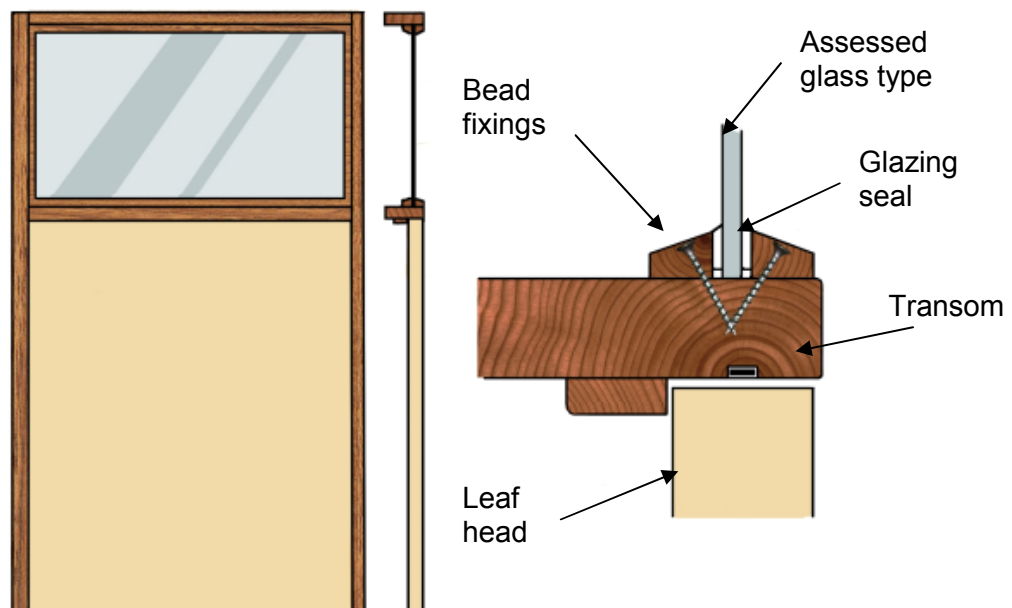

Note: Drawing is representative of doorset construction only, actual construction must be as the text within this document specifies.

7 Glazing

7.1 General

The testing conducted on the 'Flamebreak' 30 design has demonstrated that the design is capable of tolerating glazed apertures, whilst providing a margin of over performance. Glazing is therefore acceptable within the following parameters.

The maximum assessed glazed area for all configurations is 1.15m². The glazing system must be one of the following tested proprietary systems.

7.2 Assessed Glazing Systems

Glazing System	Manufacturer	Maximum Aperture Dimensions (m ²)
1. Fireglaze 30	Sealmaster Ltd	1.15
2. Firestrip 30	Hodgsons Sealants Ltd	1.15
3. Therm-A-Strip	Intumescent Seals Ltd	1.15
4. Pyroglaze 30	Mann McGowan Ltd	0.72
5. 8193	Pyroplex Ltd	0.72
6. 30049	Pyroplex Ltd	0.72
7. 30054	Pyroplex Ltd	0.72
8. System 36	Lorient Polyproducts Ltd	0.72
9. Flexible Figure 1	Lorient Polyproducts Ltd	0.72

7.3 Assessed Glass Products

Glass types (trade names)	Manufacturer
1. 6 & 7mm Pyroshield	Pilkington Group Ltd
2. 6mm Pyran S	Schott Glass Ltd
3. 6mm Pyrostem	CGI Ltd
4. 7mm Pyroguard	CGI Ltd (limited to 0.87m ²)
5. 7mm Pyrobelite	AGC Flat Glass Europe
6. 7mm Pyrodur	Pilkington Group Ltd
7. 10mm Pyrodur	Pilkington Group Ltd
8. 11mm Pyroguard	CGI Ltd (limited to 0.52m ²)
9. 11mm Pyranova 15-S2.0	Schott UK Ltd
10. 12mm Pyrobelite	AGC Flat Glass Europe
11. 15mm Pyrostop	Pilkington Group Ltd
12. 16mm Pyrobel	AGC Flat Glass Europe

Note:

- All glass types must be fitted strictly in accordance with the manufacturer's tested details/installation requirements.
- Glass types 9-12 are full insulating in terms of the criteria set out in BS 476: Part 20: 1987

7.4 Glazing Beads & Installation

Glazing beads must be from hardwood as specified in the following table:

Material	Profile	Min Density (kg/m ³)	Application
Hardwood	Splayed	640	All proprietary systems detailed in 7.2 and appendix B
Hardwood	Square	640	Proprietary systems 1,2 & 3 as specified in 7.2 and glass types 4-12 as specified in 7.3

A square bead profile may be used as an alternative to the splayed beads required for the proprietary systems, subject to the restricted glass types and glazing systems specified in the table above (see appendix B for square bead profile options).

Glazing bead fixings must be retained in position with 50mm long x 2mm diameter steel pins or 40mm long No 6-8 screws, inserted at 35-40° to the vertical at no more than 50mm from each corner and at 150mm maximum centres. Pneumatically fired pins are acceptable providing they meet the specification given above.

Glazed openings must not be less than 100mm from any door edge. Multiple apertures are acceptable within the permitted glazed area, with a minimum dimension of 80mm between apertures. Aperture shape is not restricted, providing the glazing system and beads are compatible with that shape.

False timber beads may be bonded to the glass face with an intumescent mastic/silicon, or a 0.5-2mm thick self adhesive intumescent tape/strip. Suitable glass for this application is restricted to types 4-12.

Sectional drawings detailing the tested and approved proprietary glazing systems are contained in appendix B.

8 Door Frames

8.1 Door Frame Construction

Door frames for 'Flamebreak' 30 may be timber or MDF as follows:

Material	Min Section (mm)	Min Density (kg/m ³)	Application	Leaf Size Range (mm)
Softwood/ hardwood	70 x 32*	510	All configurations	All
MDF	70 x 30	700	All configurations	All

*If the doorset features a transomed overpanel, the door frame must be softwood or hardwood (not MDF) with a minimum section of 70mm x 32mm and of the minimum densities stated above.

All door frame timber must be to class J30 as specified in BS EN 942: 2007 provided any defects are adequately repaired (see section 18 for details).

A 12mm deep planted stop is adequate for single acting frames whilst double acting frames may be scalloped or square. If frames are square, the maximum radius to the corners of the leaf is 8mm.

Frame joints may be mortice and tenoned, mitred, half lapped or butted and with no gaps (see section 8.2). All jointing methods require mechanical fixing with the appropriate size ring shank nails or screws.

All methods require joints to be tight, with no gaps, and nailed or screwed.

The following diagram depicts the assessed frame profiles and dimensions:

A = min 70mm B = min 30 - 32mm (see table above) C = min 12mm
 R = radius from floor spring 8mm max radius to create a maximum 2mm edge profiling

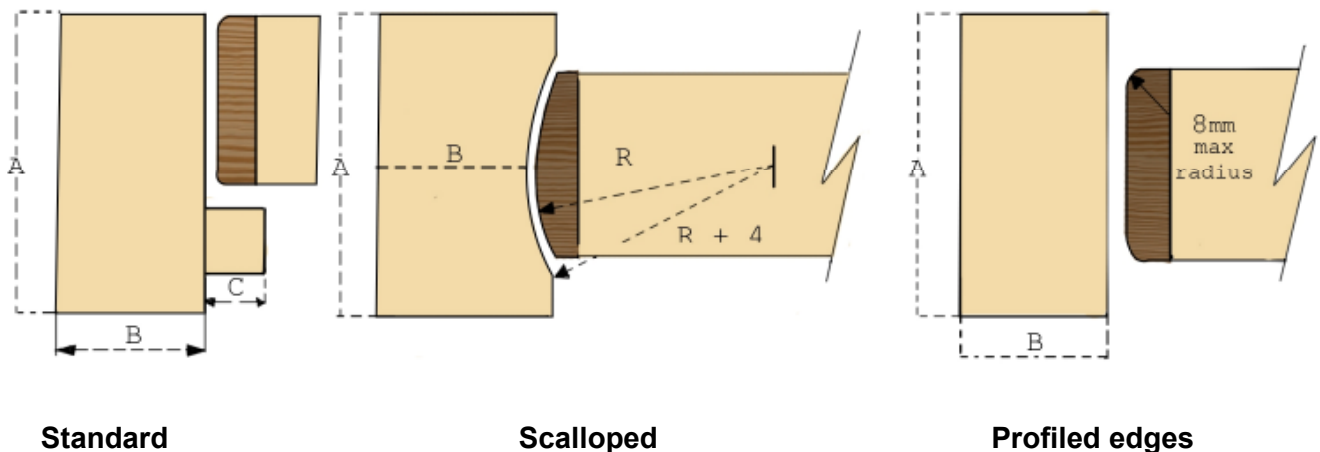

The legal validity of this report can only be claimed on presentation of the complete report.

8.2 Door Frame Joints

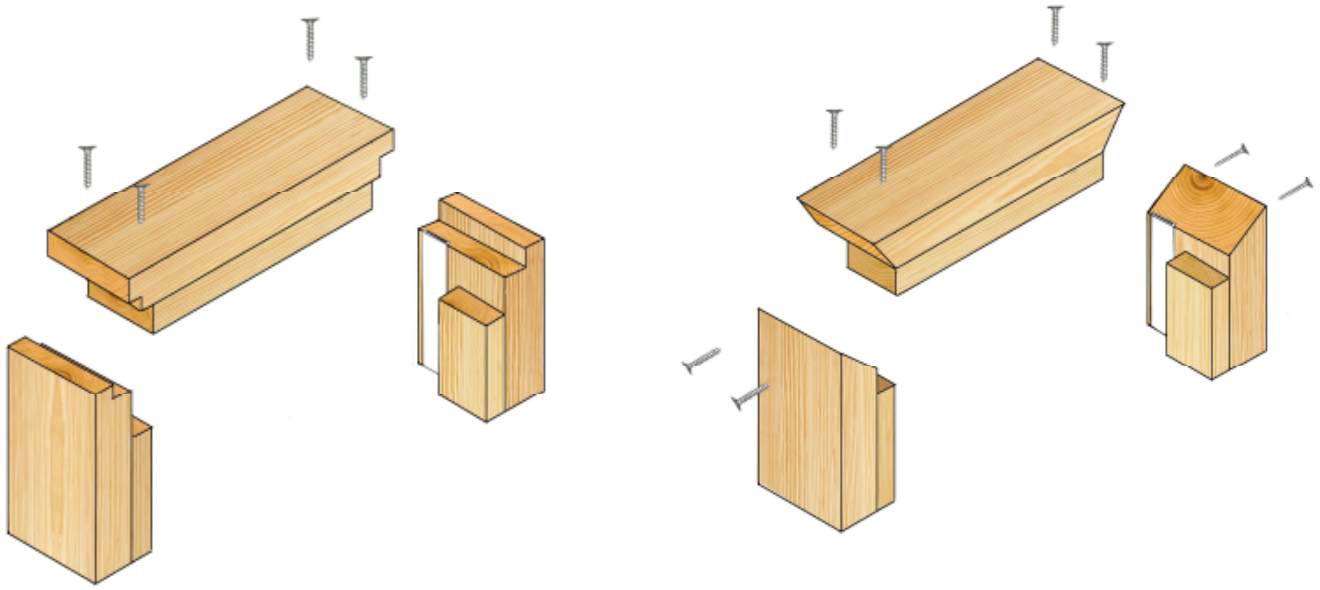

Half Lapped Joint

Mitre Joint

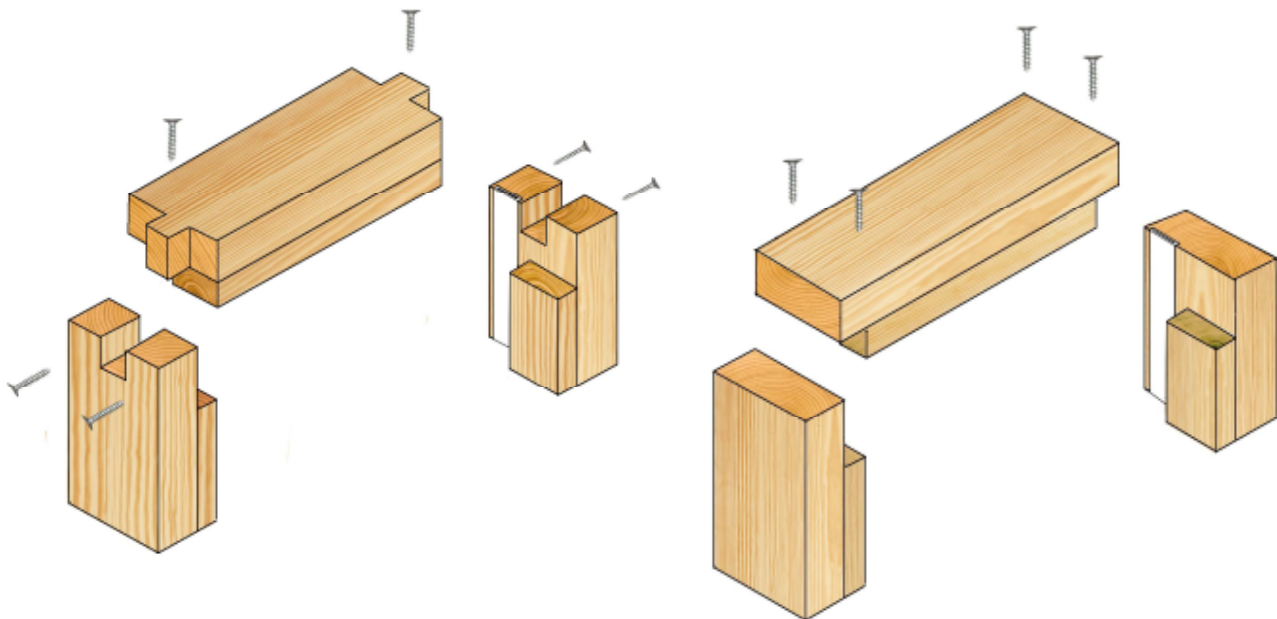

Mortise and Tenon Joint

Butt Joint

Note: Drawing is representative of each type of door frame joint, actual construction in terms of intumescent seal location and material etc. must be as the text within this document specifies

8.3 Door Frame Construction

The following diagram depicts acceptable and unacceptable door frame installations:

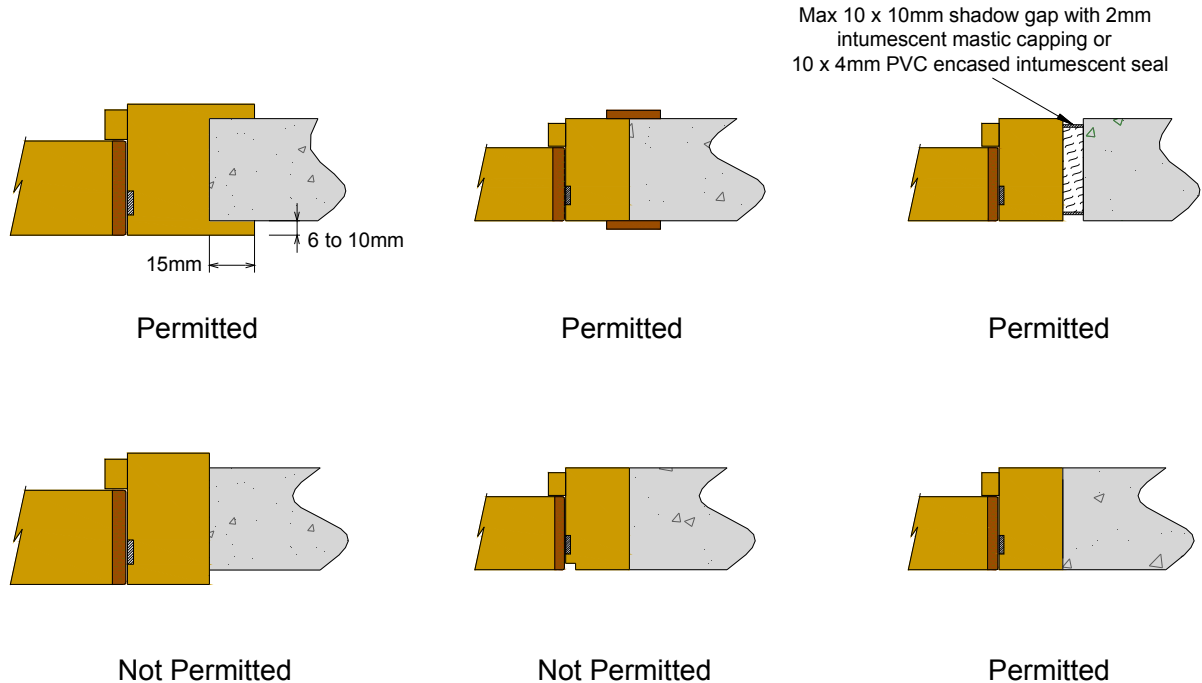

9 Edging Materials

9.1 Timber Lippings

'Flamebreak' 30 must be lipped in accordance with the following specification:

Material	Size (mm)	Min Density (kg/m ³)
Hardwood meeting or exceeding class J30 as specified in BS EN 942: 2007 (see section 18 for details).	1. Flat = 6 – 18 thick with a maximum of 2mm profiling permitted at corners of lipping (see section 8.1)	640
	2. Rounded = 8 – 20 thick with a radius matching the distance between leaf edge and floor pivot (see section 8.1)	
	3. Rebated = 20-30 thick with a 12mm deep equal rebate	

Notes:

- Single doorsets are not permitted with rebated vertical edges
- Single or double doorsets without overpanels cannot have rebated heads or jambs
- Single & double doorsets without stiles only require lipping on the vertical edges
- Doorsets with flush overpanels must be lipped on the vertical edges and additionally at the bottom edge of the overpanel and top edge of the doors
- Where applied, lippings along the vertical edges must over-run the lippings along the horizontal edges
- Double doorsets without flush overpanels are permitted with square or rebated meeting edges
- Double doorsets with flush overpanels may use a rebated overpanel junction **or** rebated meeting edges but must not use both concurrently.

10 Leaf Facing Materials

10.1 Structural Facings

The primary facing material for the 'Flamebreak' 30 doorset design is 3.6mm or 6mm thick plywood or 6mm thick MDF. Facings at this thickness are deemed as being structural and hence substitutions for alternative facings are limited. However, further testing has also demonstrated adequate performance with alternative materials. The tested and assessed alternative facings are summarised as follows:

Facing Materials	Thickness (mm)	Minimum density (kg/m ³)
Plywood	3.6, 6, 9	610
Chipboard	3.6, 6, 9	500 - 650
MDF	3.6, 6, 9	710 – 760

In each case, the overall leaf thickness must remain a minimum of 44mm; therefore the core thickness will be increased or decreased proportionally (26 – 36.8 mm thick) in relation to the facing thickness.

10.2 Decorative and Protective Facings

The following facing materials are permitted for this door design since they would degrade rapidly under test conditions without significant effect:

Facing Material	Maximum Permitted Thickness (mm)
Paint	0.5
Timber veneers	2
PVC/plastic laminates	2
Decorative paper / non-metallic foil	0.4

The legal validity of this report can only be claimed on presentation of the complete report.

Notes:

1. Metallic facings are not permitted except for push plates and kick plates (see section 14.6)
2. The door leaf thickness may be reduced by a total maximum of 0.5mm for calibration purposes in order to accommodate the chosen finish
3. Materials must not conceal intumescent strips
4. PVC/plastic laminates must not be applied to the edges of leaves

10.3 Grooves

For doorsets with 6 - 9mm facings, 3mm deep x 3mm wide feature grooves may be machined either horizontally or vertically in the facing. The grooves must not be closer than 100mm to each other or to any edge.

11 Intumescent Materials

It is important that the type, size and fitting detail for the intumescent seals remains as tested. These products can often exhibit significantly different characteristics, which could alter the performances obtained during test, and therefore they must not be considered interchangeable, irrespective of whether the product has been tested and the seal dimensions are maintained.

The intumescent materials tested for this doorset design are as follows:

Application	Location	Product/Manufacturer
Edge seals	Fitted in the frame jambs or leaf edges	<ol style="list-style-type: none"> 1. PVC encapsulated Palusol 100 – Mann McGowan 2. Pyroplex – Pyroplex Ltd 3. Type 617 – Lorient Polyproducts Ltd
Hinges	Under both blades (for leaves over 2400mm high)	<ol style="list-style-type: none"> 1. 1mm Interdens – Dufaylite Developments Ltd 2. 1mm MAP paper – Lorient Polyproducts Ltd 3. 1mm Pyrostrip 300 – Mann McGowan Fabrications Ltd 4. 1mm Therm-A-Strip – Intumescent Seals Ltd 5. 1mm G30 – Sealmaster Ltd
Lock/latches	Under forend & keep	Not required
Top pivots & flush bolts	Lining all sides of the mortices	<ol style="list-style-type: none"> 1. 2mm MAP paper - Lorient Polyproducts Ltd 2. 2mm Interdens - Dufaylite Developments Ltd 3. 2mm G30 – Sealmaster Ltd 4. 2mm Therm-A-Strip - Intumescent Seals Ltd 5. 2mm Therm-A-Flex - Intumescent Seals Ltd
Cableways	Lining the base of the groove	<ol style="list-style-type: none"> 1. 2mm MAP paper - Lorient Polyproducts Ltd 2. 2mm Interdens - Dufaylite Developments Ltd 3. 2mm G30 – Sealmaster Ltd 4. 2mm Therm-A-Strip - Intumescent Seals Ltd 5. 2mm Therm-A-Flex - Intumescent Seals Ltd

The seal specification for each configuration is shown in appendix D.

The legal validity of this report can only be claimed on presentation of the complete report.

12 Adhesives

The following adhesives must be used in construction:

Element	Product
Facings	Melamine or PVA
Lipping	Urea formaldehyde, resorcinol formaldehyde, PU
Core	PVA

13 Tested Hardware

The following hardware has been successfully incorporated in the tests on this design:

1. Royde & Tucker H105 steel butt hinges.
2. 100mm x 32mm Stainless steel butt hinges.
3. Dorma TS71 & TS73V & TS83V overhead closers.
4. Henderson Hardware 63mm tubular mortice latch with aluminium lever handles.
5. E*S Hardware 88mm tubular mortice latch with aluminium lever handles.
6. Nemeff latch (235mm x 20mm forend) with stainless steel lever handles.

14 Additional & Alternative Hardware

14.1 Latches and locks

Latches and locks must either be as tested, or alternatively components with the following specification are acceptable:

Element	Dimensions (mm)
Maximum forend and strike plate dimensions:	235 high by 24 wide by 4 thick
Maximum body dimensions:	18 thick by 100 wide by 165 high.
Intumescent protection:	Not required
Materials:	All parts essential to the locking/latching action (including the latch bolt, forend and strike) to be steel or brass (with melting point $\geq 800^{\circ}\text{C}$)

14.2 Hinges

'Flamebreak' 30 leaves must be hung on a minimum of 3 hinges. Leaves over 2400mm high must fit 4 hinges. Hinges with the following specification are acceptable:

Element		Specification	
Blade height:		90 - 120mm	
Blade width (excluding knuckle):		30 - 35mm	
Blade thickness		2.5 - 4mm	
Fixings:		Minimum of 4 No. 30 long No. 8 or No.10 steel wood screws per blade	
Materials:		Steel or stainless steel or brass (melting point = or > 800°C)	
Hinge positions:	Leaf dimensions <2400mm:	Top	150 -180mm from the head of the leaf to the top of the hinge
		2 nd	Minimum 200mm from top hinge to central between top and bottom hinge
		Bottom	180 - 250mm from the foot of the leaf to the bottom of the hinge
	Leaf dimensions >2400mm:	Top	150-180mm from the head of the leaf to the top of the hinge
		2 nd & 3 rd	Equispaced between top and bottom
		Bottom	180 - 250mm from the foot of the leaf to the bottom of the hinge
Intumescent protection:		See section 11	

14.3 Automatic Closing

Automatic closing devices, must either be as tested or components of equal specification that have demonstrated contribution to the required performance of these types of 30 minute doorset design, when tested to BS 476: Part 22: 1987 or BS EN 1634-1: 2000.

Note: The top pivots to floorspring assemblies must be protected with 2mm thick intumescent gasket (see section 11) or alternatively the manufacturers tested intumescent gaskets.

14.4 Flush Bolts

Flush bolts may be incorporated centrally into the top and bottom of one meeting edge, providing the following maximum dimensions are not exceeded and the components are fitted opposite the edge fitted with intumescent strips:

- 200mm long x 20mm deep x 20mm wide.

Flush bolts must be steel or brass and the mortice must be as tight to the mechanism as is compatible with its operation. All edges of the mortice must be protected with intumescent gaskets as specified in section 11. Alternatively the hardware manufacturers tested gaskets may be used. See diagram below for example of intumescent protection to flush bolt.

The legal validity of this report can only be claimed on presentation of the complete report.

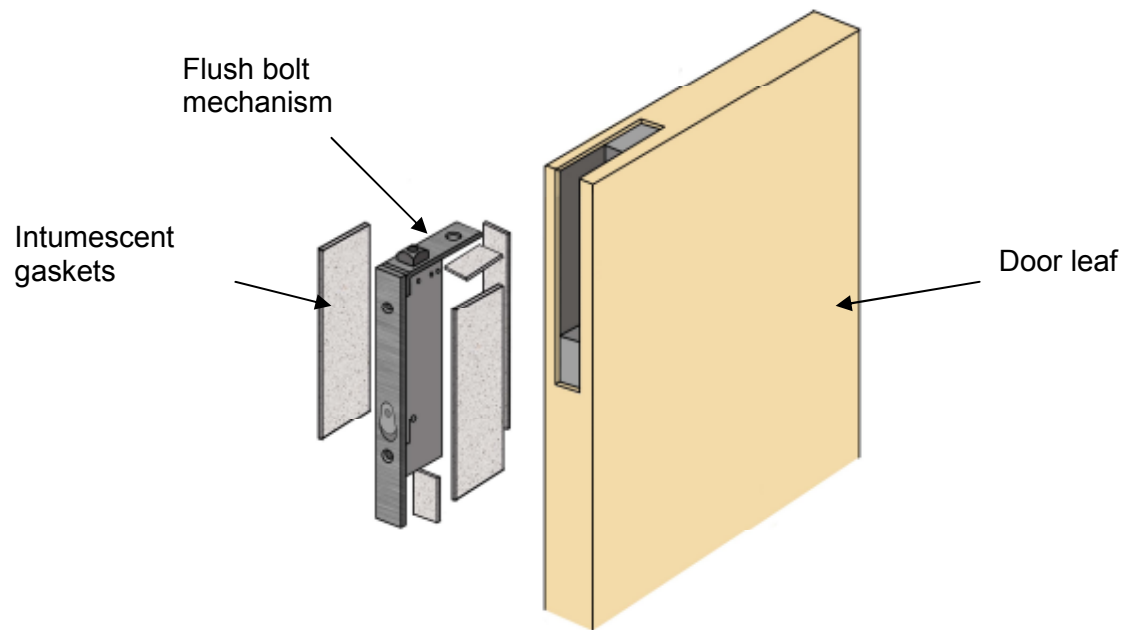

14.5 Pull Handles

These may be surface-fixed to the door leaf provided that they are steel or brass and the length is limited to 1200 mm between the fixing points. No additional intumescent protection is required provided that the hole for the bolt through the leaf is tight.

14.6 Push Plates/Kick Plates

Face-fixed hardware such as push plates and kick plates may be fitted to the doorsets provided that their fitting requires the removal of no part of the door leaf. These items of hardware must not amount to more than 20% of the door leaf area if mechanically fixed and a maximum of 30% if bonded with a contact or other thermally softening adhesive. Plates must not return around the door edges.

14.7 Door Selectors

These may be freely applied, provided that they are not invasive in the leaf edges or door frames and they do not interfere with the self-closing action of the door leaf. Products that are invasive will require fire resistance test/assessment evidence to support their use.

14.8 Door Security Viewers

Door security viewers with brass or steel bodies of a diameter less than or equal to 15mm may be used provided that the through-hole is bored tight to the case of the viewer (maximum tolerance +1 mm). Lenses must be glass and the item must be bedded in to a tested intumescent mastic.

14.9 Panic Hardware

Panic hardware may be fitted, provided that its installation does not require the removal of any timber from the leaf, stop or frame reveal and it in no way interferes with the self-closing action of the door leaf.

14.10 Air Transfer Grilles

Air transfer grilles may be fitted providing the product has suitable test evidence to BS 476: Part 22: 1987 or BS EN 1634-1: 2000 that demonstrates a minimum 30 minutes integrity performance when installed within a timber based doorset of comparable thickness. Margins to the leaf edges will remain as detailed for glazing and the position of the unit will be dictated by the pressure regime tested in the proving evidence (normally below mid height). The area occupied by the air transfer grille must not exceed 0.2m² and must be deducted from the percentage of glazing, if both elements are fitted.

14.11 Acoustic, Weather and Dust Seals

Silicon based flame retardant acoustic, weather and dust seals (e.g. Lorient IS1212, IS1511, IS7025, IS7060) may be fitted to this doorset design without compromising the performance, providing their fitting does not interfere with the activation of the intumescent seals or hinder the self closing function of the leaves:

14.12 Threshold Seals

The following types of automatic threshold drop seals may be recessed in to the bottom rail of leaves to this design with out compromising the performance:

Lorient Polyproducts	IS8010si
Raven	RP8
Athmer	Schall-Ex Duo L-15
Norseal	810

Alternative products may be used providing they are essentially of the same construction, materials and dimensions.

14.13 Cable-Way

Based on the integrity performance of the doorset construction, with no burn through of the core material, we consider it acceptable to allow the provision for a concealed cable-way to facilitate electro-magnetic closing/latching mechanisms. This approval is subject to the hardware manufacturer having the appropriate test evidence for the product for use with this type of 30 minute construction. The cable-way must be concealed in one of the following ways:

1. A central 8mm x 8mm groove in the edges of the core from mid height on one edge passing around the bottom of the leaf and returning up the opposite edge. The base of the groove must be lined with 2mm thick intumescent gasket (see top pivots & flush bolts in section 11) and the lipping bonded over the top of the wire-way.
2. A hole drilled centrally through the leaf of maximum 8mm diameter. The hole must be lined with a 2mm thick intumescent gasket (see top pivots & flush bolts in section 11). This option is only permitted for use with latched, single leaf, single acting doorsets with maximum leaf dimensions of 2100mm (h) x 900mm (w). The hole must be located below 1500mm from the threshold and must be spaced a minimum of 90mm from any apertures within the leaf e.g glazing, air transfer grilles or letter plates etc.

14.14 Letter Boxes/Plates

Letter boxes/plates may be fitted providing the product can demonstrate contribution to the required performance of this type of 30 minute doorset design, when tested to BS 476: Part 22: 1987 or BS EN 1634-1: 2000 and installed at the proposed location, within a timber based doorset of comparable thickness. Margins to the leaf edges must remain as specified for glazing.

15 Door Gaps

Door edge gaps, threshold gaps, and alignment tolerances, must fall within the range shown in the following table:

Location	Dimension
Door edge gaps	A minimum of 2mm and a maximum of 4mm.
Alignment tolerances	Leaves must not be proud of each other or from the door frame by more than 1mm.
Threshold	10mm between bottom of leaf and top of floor covering

16 Structural Opening

The supporting construction must provide the required level of fire resistance designated for the doorset design and be a suitable medium to permit adequate fixity.

17 Fixings

The frame jambs are to be fixed to the supporting construction using steel fixings at 600mm maximum centres. The fixings must be of the appropriate type for the supporting construction and must penetrate to a minimum depth of 40mm. It is not necessary to fix the frame head, although packers must be inserted.

18 Classification of Timber

All timber used for door frames, lipping and glazing beads, must meet or exceed class J30 as specified in BS EN 942: 2007, providing any defects are adequately repaired.

19 Sealing to Structural Opening

The door frame to structural opening gap must be protected using one of the following methods:

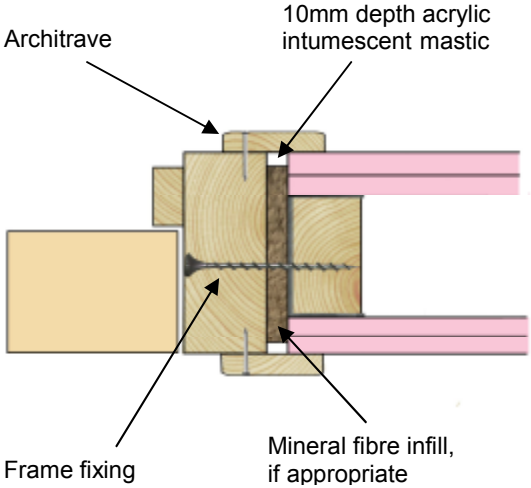
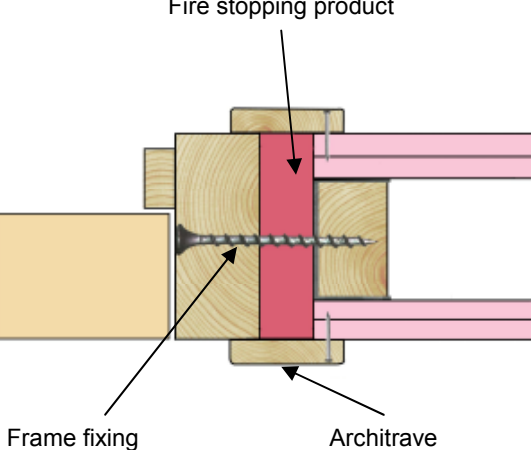
<p>1)</p>	<p>Gaps up to 10mm must be sealed on both sides with a 10mm depth of acrylic intumescent mastic, fire tested for this application to BS 476: Part 22: 1987 or BS EN 1634-1: 2000.</p>	
<p>2)</p>	<p>Gaps between 10mm and 20mm must be tightly packed with mineral fibre capped on both sides with a 10mm depth of acrylic intumescent mastic, fire tested for this application to BS 476: Part 22: 1987 or BS EN 1634-1: 2000.</p>	
<p>3)</p>	<p>Gaps up to 20mm must be filled with proprietary fire stopping product (e.g. expanding PU foam or preformed compressible intumescent foam). Products must be tested for this application to BS 476: Part 22: 1987 or BS EN 1634-1: 2000.</p>	

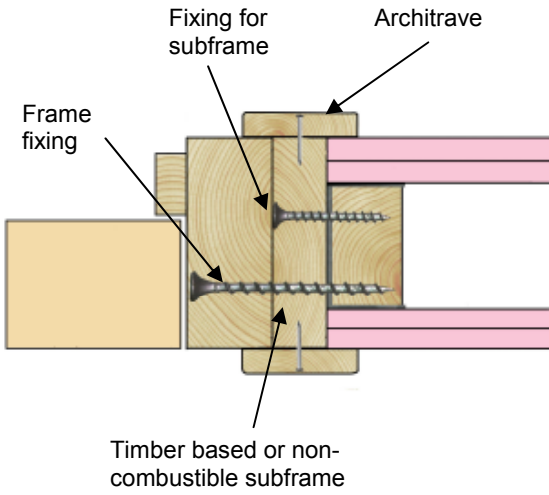
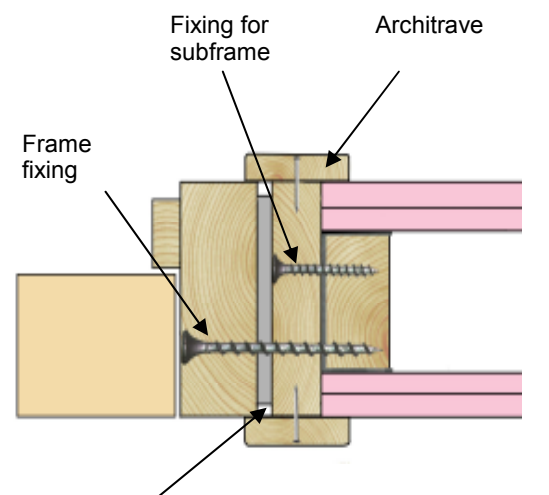
<p>4)</p>	<p>Gaps up to 40mm must be filled with full depth timber or timber based composite material or non-combustible subframe up to 40mm thick, with no gaps between the components and fitted with a minimum of 10mm thick architraves</p>	 <p>Labels in diagram: Fixing for subframe, Architrave, Frame fixing, Timber based or non-combustible subframe</p>
<p>5)</p>	<p>Gaps greater than 20mm require a full depth timber or timber based composite material or non-combustible subframe. Gaps up to 10mm between components must be sealed on both sides with a 10mm depth of appropriately fire tested acrylic intumescent mastic or full depth expanding PU foam. Gaps between 10mm and 20mm must be fire stopped as described in either point 2 or 3 above. Products must be tested for this application to BS 476: Part 22: 1987 or BS EN 1634-1: 2000.</p>	 <p>Labels in diagram: Fixing for subframe, Architrave, Frame fixing, 10mm depth acrylic intumescent mastic</p>

Guidance for various methods of sealing the frame to structural opening gap is also given in BS 8214: 2008, “Code of practice for fire door assemblies”, which may be referred to where appropriate.

Note: Drawings are representative of doorset installation only, actual installations must be as the text within this document specifies.

20 Insulation

Insulation performance may be claimed for a doorset to this design meeting the following:

Type	Details
Partially insulating	Doorsets incorporating up to 20% of non-insulating glazing
Fully insulating	Doorsets unglazed or including 30 minute insulating glazing (e.g. 15mm Pyrostop or 16mm Pyrobel)

The legal validity of this report can only be claimed on presentation of the complete report.

21 Smoke Control

If the doorset design is required to provide a smoke control function to comply with Building Regulations, then it must be fitted with a smoke seal or combined intumescent/smoke seal, that has been tested in accordance with BS 476: Part 31: Section 31.1 and demonstrated to maintain the leakage rate below 3m³/m/h when tested at 25Pa.

Providing the smoke seals, any interruptions, door gaps, type/configuration of door is consistent with the tested detail, then the doorset will comply with current smoke control legislation and a suffix 'S' may be added to the designation. Any other installed components where smoke leakage may occur must also be taken into account e.g. air transfer grilles.

Note: The incorrect specification and fitting of smoke seals may impair the operation of a fire resisting doorset assembly such that integrity is reduced, or in the extreme case completely diminished.

22 Conclusion

If 'Flamebreak' 30 doorsets, constructed in accordance with the specification documented in this global assessment, were to be tested in accordance with BS 476 : Part 22 : 1987, it is our opinion that they would provide a minimum of 30 minutes integrity and insulation (subject to section 20).

23 Declaration by the Applicant

1. We the undersigned confirm that we have read and comply with obligations placed on us by FTSG Resolution No 82: 2001.
2. We confirm that the component or element of structure, which is the subject of this assessment, has not to our knowledge been subjected to a fire test to the Standard against which this assessment is being made.
3. We agree to withdraw this assessment from circulation should the component or element of structure be the subject of a fire test to the Standard against which this assessment is being made.
4. We are not aware of any information that could adversely affect the conclusions of this assessment.
5. If we subsequently become aware of any such information we agree to ask the assessing authority to withdraw the assessment.

Signed



PACIFIC RIM WOOD
S. Hansen
LIMITED

Name:

For and on behalf of Pacific Rim Wood Ltd

24 Limitations

The following limitations apply to this assessment:

1. This assessment addresses itself solely to the elements and subjects discussed and does not cover any other criteria. All other details not specifically referred to should remain as tested or assessed.
2. This assessment is issued on the basis of test data and information to hand at the time of issue. If contradictory evidence becomes available, CIF reserves the right to withdraw the assessment unconditionally but not retrospectively.
3. This assessment has been carried out in accordance with Fire Test Study Group Resolution No 82: 2001.
4. Opinions and interpretations expressed herein are outside the scope of UKAS accreditation.
5. This assessment relates only to those aspects of design, materials and construction that influence the performance of the element(s) under fire resistance test conditions. It does not purport to be a complete specification ensuring fitness for purpose and long-term serviceability. It is the responsibility of the client to ensure that the element conforms to recognised good practice in all other respects and that, with the incorporation of the guidance given in this assessment, the element is suitable for its intended purpose.

25 Validity

1. The assessment is initially valid for five years after which time it must be submitted to CIFL for technical review.
2. This assessment report is not valid unless it incorporates the declaration given in Section 23 duly signed by the applicant.

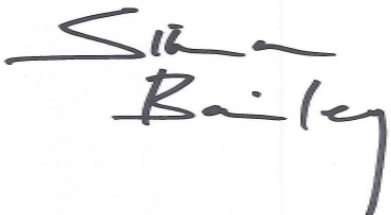
Signature:		
Name:	P N Barker	S Bailey
Title:	Senior Consultant	Product Assessor

The legal validity of this report can only be claimed on presentation of the complete report.

Appendix A

Performance Data

Primary Data

Test Reference	Configuration	Leaf Size (mm)	Test Standard	Integrity (min)
RF98033	ULSADD	2135 x 915 x 45	BS 476: Part 22: 1987	36
RF98075	2 No. ULSASD	A = 2055 x 865 x 44 B = 2135 x 916 x 44	BS 476: Part 22: 1987	A = 31 B = 33
RF00044 (stiles & rails no lippings)	2 No. ULSASD	2080 x 915 x 44	BS 476: Part 22: 1987	A = 19 B = 31
RF00046 (stile removed lippings vertical edges only)	ULSADD	2135 x 835 x 44	BS 476: Part 22: 1987	32
RF00098 (stiles & top rail only)	2 No. ULSASD	A = 2080 x 916 x 44 B = 2080 x 860 x 44	BS 476: Part 22: 1987	A = 32 B = 33
RF00166 (lipped & unlipped)	ULSASD	A = 2440 x 1220 x 44 B = 2390 x 1154 x 44	BS 476: Part 22: 1987	A = 37 B = 41
RF04011	LSASD	1976 x 758 x 44	BS 476: Part 22: 1987	31
Warres 138803	ULSASD	2034 x 926 x 44	BS 476: Part 22: 1987	36
RF05041 (stile removed & lipped vertical edges only with rebated ME)	ULSADD	2041 x 825 x 44	BS 476: Part 22: 1987	39

The legal validity of this report can only be claimed on presentation of the complete report.

Test Reference	Configuration	Leaf Size (mm)	Test Standard	Integrity (min)
RF08100 (P.U gluelines for lipping, large glazed apertures – ply and MDF faces)	A: ULSADD	A: 2100 x 900/350 x 44	BS 476: Part 22: 1987	A: 39
	B: ULSASD	B: 2100 x 900 x 44	BS 476: Part 22: 1987	B: 51
RF08116 (10 x 4 Pyroplex with ply and MDF faces)	A: ULSASD	A: 2040 x 826 x 44	BS 476: Part 22: 1987	A: 45
	B: ULSASD	B: 2040 x 826 x 44	BS 476: Part 22: 1987	B: 35
RF08118 (Large ply face doorsets with overpanel and rebated head junction with Pyroplex)	ULSADD + OP	2400 x 1000 x 44 + 400 OP	BS 476: Part 22: 1987	41
WF137714 (Pyroplex glazing system 30054)	Indicative	990 x 900 x 44	BS 476: 20: 1987	41
WF139878 (Pyroplex glazing system 30049)	Indicative	990 x 990 x 44	BS 476: Part 20: 1987	29 (failure attributed to glass not glazing system)

Supplementary Data

Test Reference	Configuration	Leaf Size (mm)	Test Standard	Integrity (min)
RF09105 (A: 20 x 4mm & B: 15 x 4mm Pyroplex with MDF facings)	A: ULSADD B: ULSADD	Both 2145 x 927 x 44	BS EN 1634-1: 2000	35
A07051 Rev B (assessment of Lorient Type 617 seals)	Various	Various	BS 476: Part 22: 1987	30 and 60

The legal validity of this report can only be claimed on presentation of the complete report.

Appendix B

Proprietary 30 Minute Glazing Systems

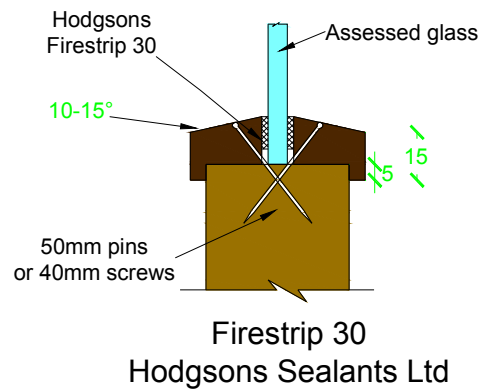
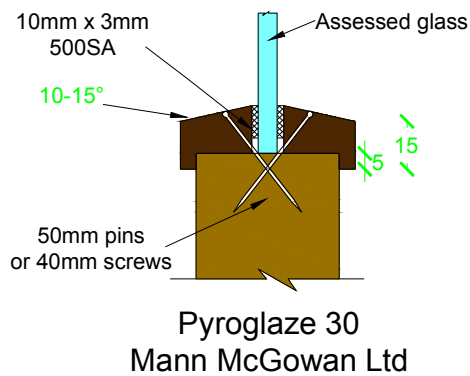
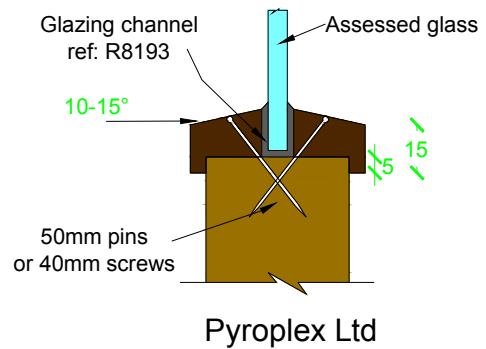
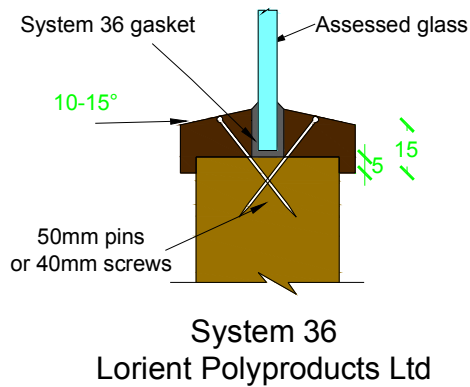
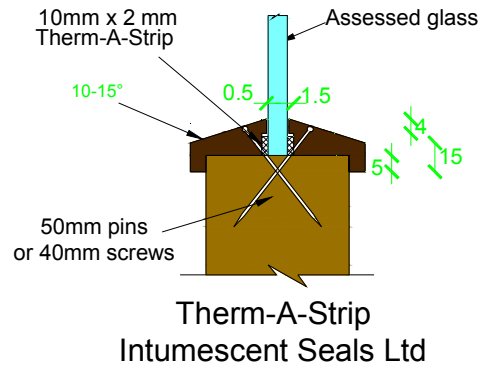
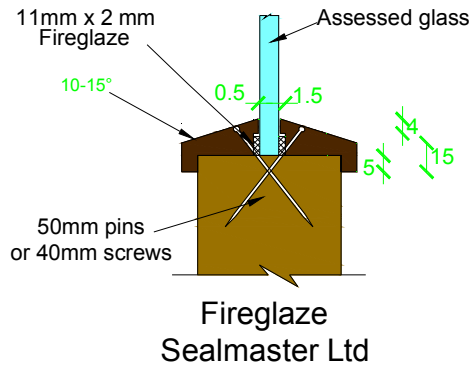

The legal validity of this report can only be claimed on presentation of the complete report.

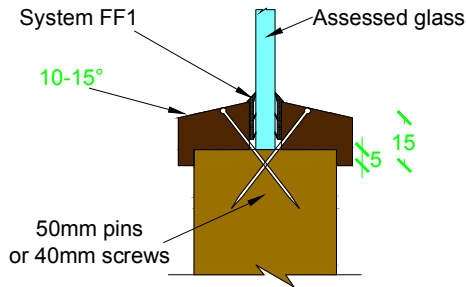

System FF1
Lorient Polyproducts Ltd

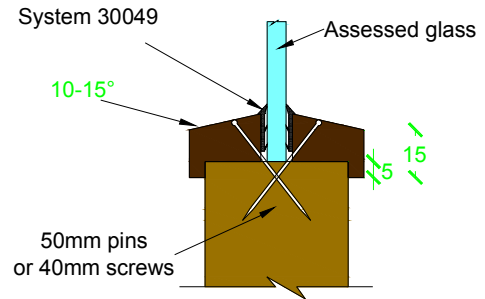

System 30049
Pyroplex Ltd

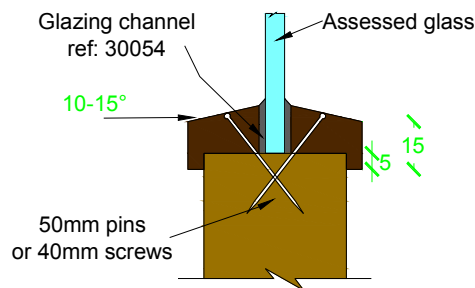

Glazing channel ref: 30054
Pyroplex Ltd

Assessed Square Glazing Bead Profiles

(The following square bead profiles may be used as an alternative to the splayed beads detailed above - refer to section 7 for glazing system and glass restrictions)

To finish flush with the leaf face

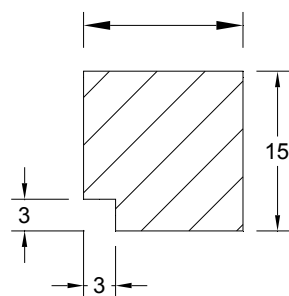

Suited to glass thickness

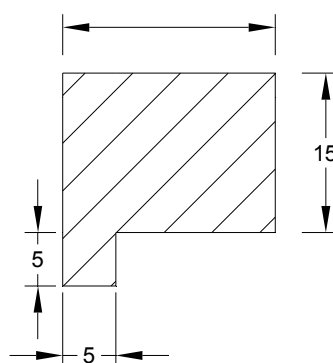

To finish flush with the leaf face

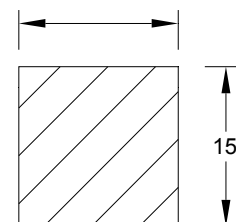

The legal validity of this report can only be claimed on presentation of the complete report.

Appendix C

Revisions

Revision	CIFL Reference	Date	Description
A	FEA/F00125	01.08.00	Inclusion of additional test evidence to justify the use of further facing materials. Recalculation of maximum approved leaf dimensions and justification for the alteration of leaf size.
B	Chilt/A01032	26.02.01	<ol style="list-style-type: none"> 1. Inclusion of test evidence RF00166 and re-calculation of size range. 2. Assessment of facing range for 2440 x 1220 max leaf size. 3. Assessment of softwood door frames for 2440 x 1220 max leaf size
C	Chilt/A02194	04.10.02	Revalidation for a further five year period and minor alterations to the report format.
D	Chilt/A04051	09.6.04	Inclusion of test evidence from RF04011 including feature grooves and 6mm lippings.
E	Chilt/A05159	08.09.05	Revalidation for a further five year period and inclusion of test evidence from RF05041 including rebated meeting edges and alternative thickness' of face materials.
F	Chilt/A07168	20.8.07	Inclusion of Lorient Type 617 intumescent seals and revalidation for 5 years
G	Chilt/A08228	4.12.08	Inclusion of PU gluelines for lipping doors, glazed apertures to 1.44m ² , MDF door frames, coverage for 10 x 4 Pyroplex seals (design limitations apply), overpanels with a flush and rebated junction, Lorient Type 617 written into a separate Flamebreak document, addition of Pyroplex glazing system 30054 based on WF137714, addition of Pyroplex glazing system based on WF30049
H	Chilt/A09152	22.12.09	Technical review and update of assessment format; evidence from test RF09105 to BS EN 1634-1 incorporated into document - Lorient Type 617 perimeter seals and large single leaf doors with Pyroplex seals. Amendment to facing thickness
I	Chilt/A09152 Rev I	22.07.10	Edit to intumescent gaskets required for flush bolts and top pivots

The legal validity of this report can only be claimed on presentation of the complete report.

Appendix D

Data Sheets for:

Pacific Rim Wood Ltd

'Flamebreak' 30 Doorsets

30 Minutes Fire Resistance

Pacific Rim Wood Ltd – ‘Flamebreak’ 30 Doorsets

Latched & Unlatched Single Acting & Double Acting Single Doorsets – Pyroplex Rigid Box Seal

All assessed facing types						
Leaf Sizes	Configuration		Height (mm)		Width (mm)	
	LSASD	From:		2145	x	1067
		To:		2463	x	927
ULSASD & DASD	From:		2145	x	1042	
	To:		2413	x	927	
Maximum Overpanel height (mm)	Transomed		2000			
Glazing	Maximum Glazed Area:		1.15m ² (see section 7 for details)			
	Approved systems:		See section 7 and appendix B			
Frame specification	Min. Section (mm):		70 x 32	70 x 32	70 x 30	
	Material:		Softwood	Hardwood	MDF	
	Min. Density (kg/m ³):		510	510	700	

Intumescent Materials: PVC encapsulated Pyroplex Rigid Box Seal

Head: 1 No 15 x 4mm PVC encapsulated Pyroplex fitted centrally in the leaf edge or frame reveal. Increase to 20 x 4mm for leaves that use 9mm thick MDF facings.

Jamb: 1 No 15 x 4mm PVC encapsulated Pyroplex fitted centrally in the leaf edge or frame reveal. Increase to 20 x 4mm for leaves that use 9mm thick MDF facings.

Hardware Protection: see section 11

Maximum Door Leaf Size

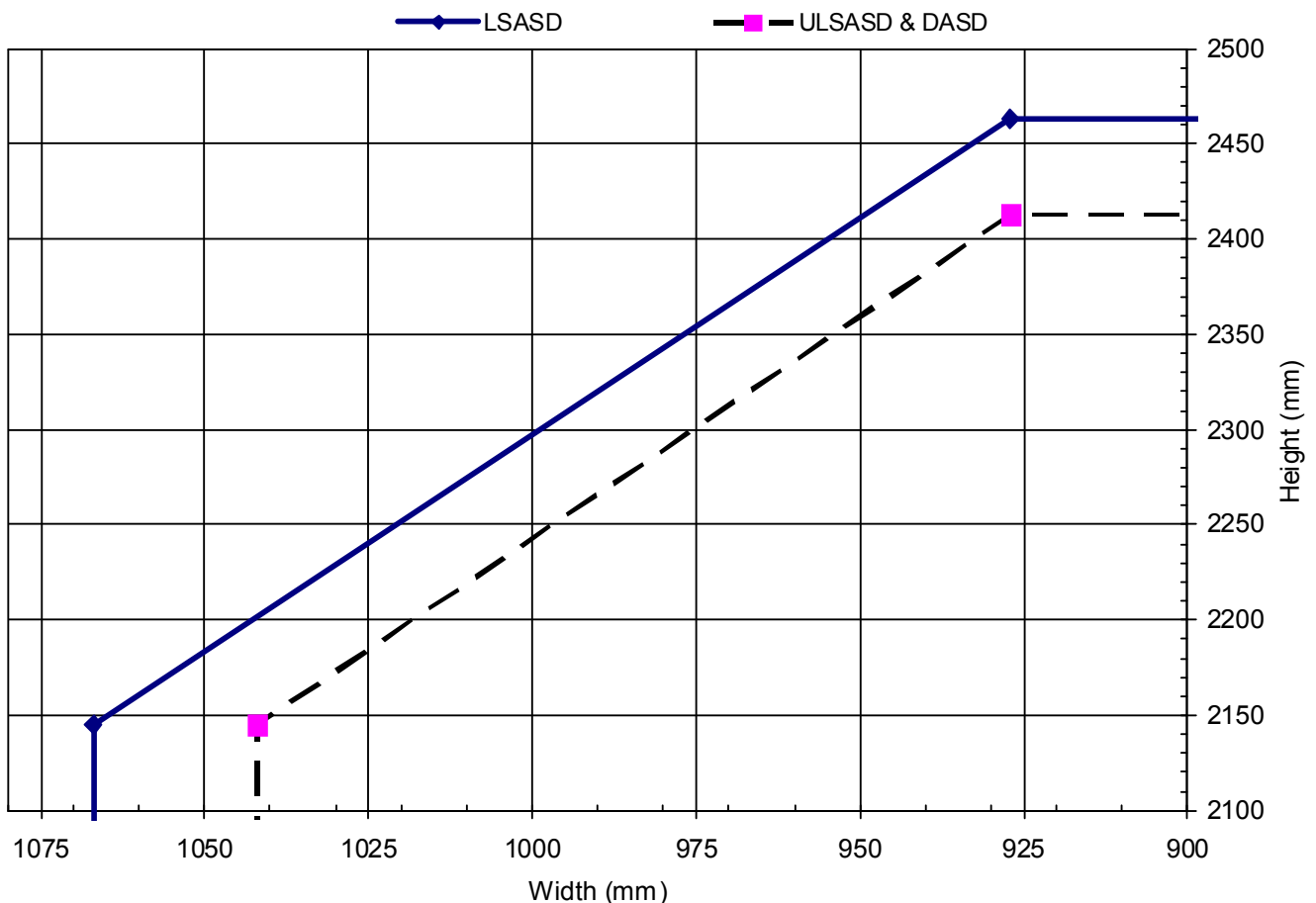

The legal validity of this report can only be claimed on presentation of the complete report.

Pacific Rim Wood Ltd – ‘Flamebreak’ 30 Doorsets
Latched Single Acting Single Doorsets – Palusol or Type 617

Leaf Sizes	Facing Type		Height (mm)		Width (mm)
	3.6mm thick Plywood	From:	2390	x	1387
		To:	2870	x	1154
	All other assessed facing types	Max:	2440	x	1220
Maximum Overpanel height (mm)		Transomed	2000		
Glazing		Maximum Glazed Area:	1.15m ² (see section 7 for details)		
		Approved systems:	See section 7 and appendix B		
Frame specification		Min. Section (mm):	70 x 32	70 x 32	70 x 30
		Material:	Softwood	Hardwood	MDF
		Min. Density (kg/m ³):	510	510	700
Intumescent Materials: PVC encapsulated Palusol 100 or Type 617					
Head: 1 No 15 x 4mm seal fitted centrally in the leaf edge or frame reveal. Increase to 20 x 4mm for leaves that use 9mm thick MDF facings. Leaves over 2390mm high increase to 25 x 4mm.					
Jamb: 1 No 15 x 4mm seal fitted centrally in the leaf edge or frame reveal. Increase to 20 x 4mm for leaves that use 9mm thick MDF facings. Leaves over 1100mm wide increase to 25 x 4mm.					
Hardware Protection: see section 11					

Maximum Door Leaf Size

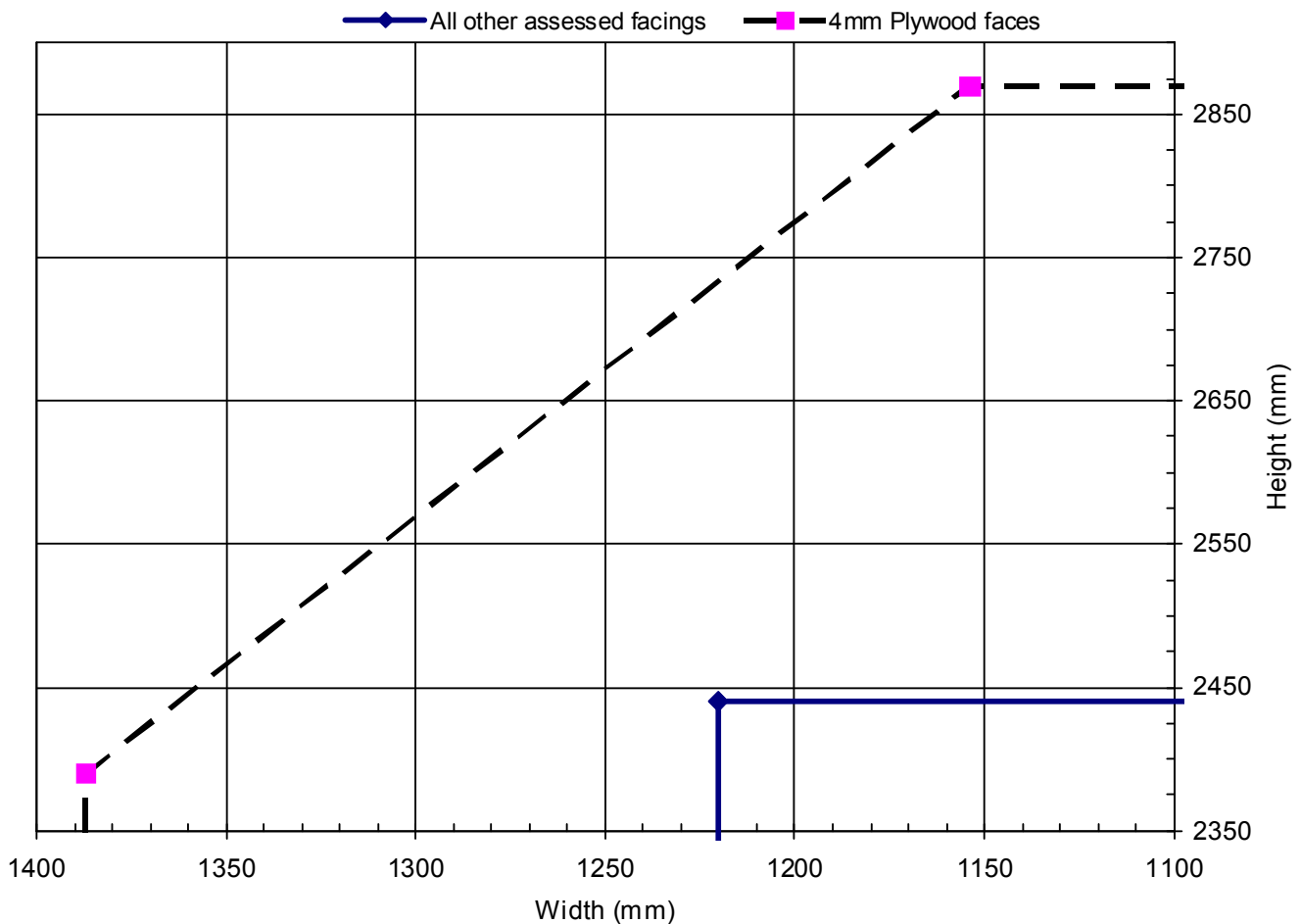

The legal validity of this report can only be claimed on presentation of the complete report.

Pacific Rim Wood Ltd – ‘Flamebreak’ 30 Doorsets

Unlatched Single Acting & Double Acting Single Doorsets – Palusol or Type 617

Leaf Sizes	Facing Type	From:	Height (mm)			Width (mm)
	3.6mm thick Plywood	From:	2390	x	1362	
		To:	2820	x	1154	
All other assessed facing types	Max:	2440	x	1220		
Maximum Overpanel height (mm)	Transomed		2000			
Glazing	Maximum Glazed Area:		1.15m ² (see section 7 for details)			
	Approved systems:		See section 7 and appendix B			
Frame specification	Min. Section (mm):		70 x 32	70 x 32	70 x 30	
	Material:		Softwood	Hardwood	MDF	
	Min. Density (kg/m ³):		510	510	700	
Intumescent Materials: PVC encapsulated Palusol 100 or Type 617 Head: 1 No 15 x 4mm seal fitted centrally in the leaf edge or frame reveal. Increase to 20 x 4mm for leaves that use 9mm thick MDF facings. Leaves over 2390mm high increase to 25 x 4mm. Jambs: 1 No 15 x 4mm seal fitted centrally in the leaf edge or frame reveal. Increase to 20 x 4mm for leaves that use 9mm thick MDF facings. Leaves over 1100mm wide increase to 25 x 4mm. Hardware Protection: see section 11						

Maximum Door Leaf Size

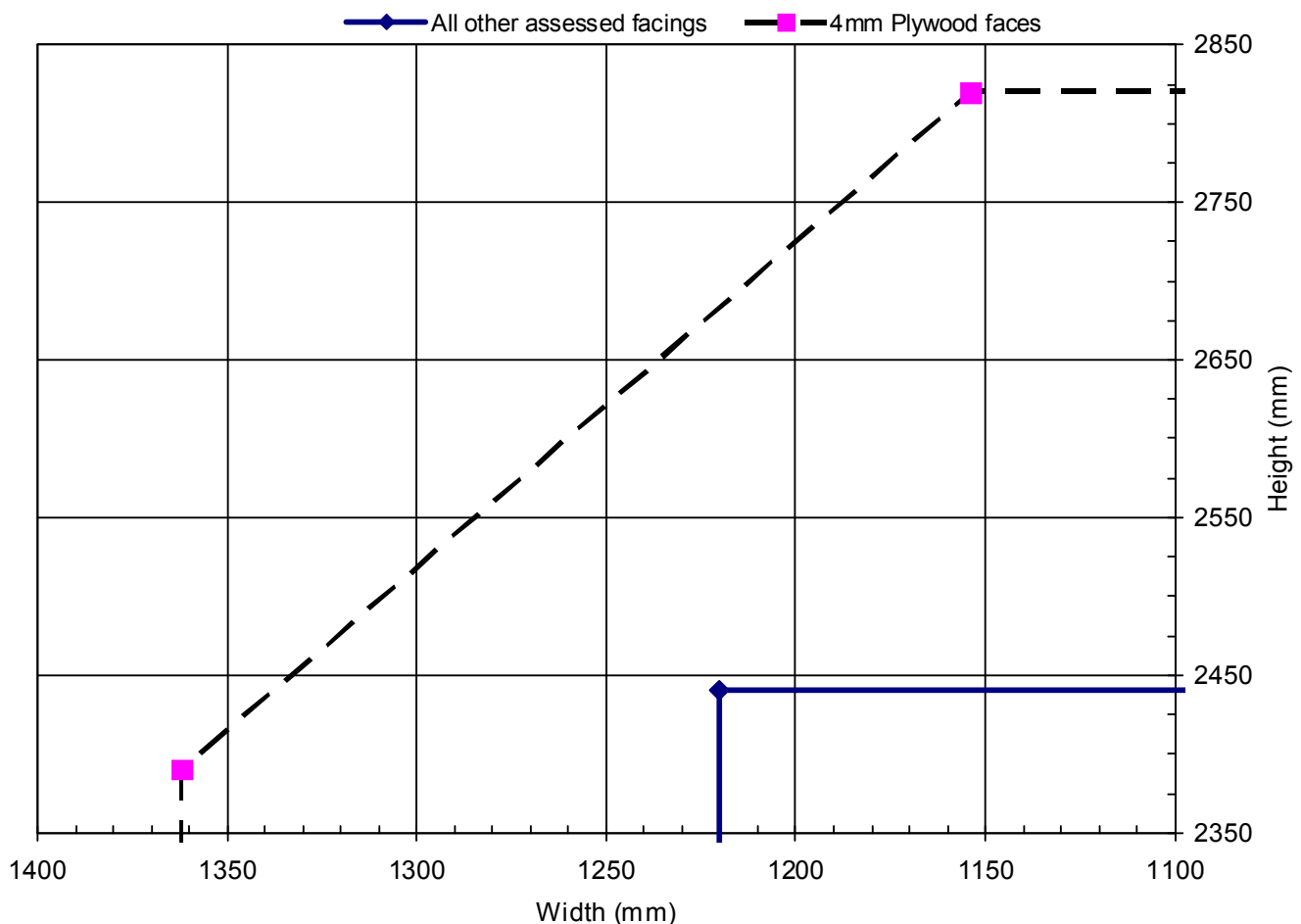

The legal validity of this report can only be claimed on presentation of the complete report.

Pacific Rim Wood Ltd – ‘Flamebreak’ 30 Doorsets

Latched & Unlatched Single Acting & Double Acting Single Doorsets – Pyroplex Rigid Box Seal

Facing Type: 6mm MDF						
Leaf Sizes	Configuration		Height (mm)		Width (mm)	
	LSASD	From:	2040	x	1057	
		To:	2600	x	826	
ULSASD & DASD	From:	2040	x	1032		
	To:	2550	x	826		
Maximum Overpanel height (mm)	Transomed	2000				
Glazing	Maximum Glazed Area:	1.15m ² (see section 7 for details)				
	Approved systems:	See section 7 and appendix B				
Frame specification	Min. Section (mm):	70 x 32	70 x 32	70 x 30		
	Material:	Softwood	Hardwood	MDF		
	Min. Density (kg/m ³):	510	510	700		
Intumescent Materials: PVC encapsulated Pyroplex Rigid Box Seal						
Head: 1 No 10 x 4mm fitted centrally in the leaf edge or frame reveal. Leaves over 2300mm high increase to 15 x 4mm.						
Jamb: 1 No 10 x 4mm fitted centrally in the leaf edge or frame reveal. Leaves over 2300mm high increase to 15 x 4mm.						
Hardware Protection: see section 11						

Maximum Door Leaf Size

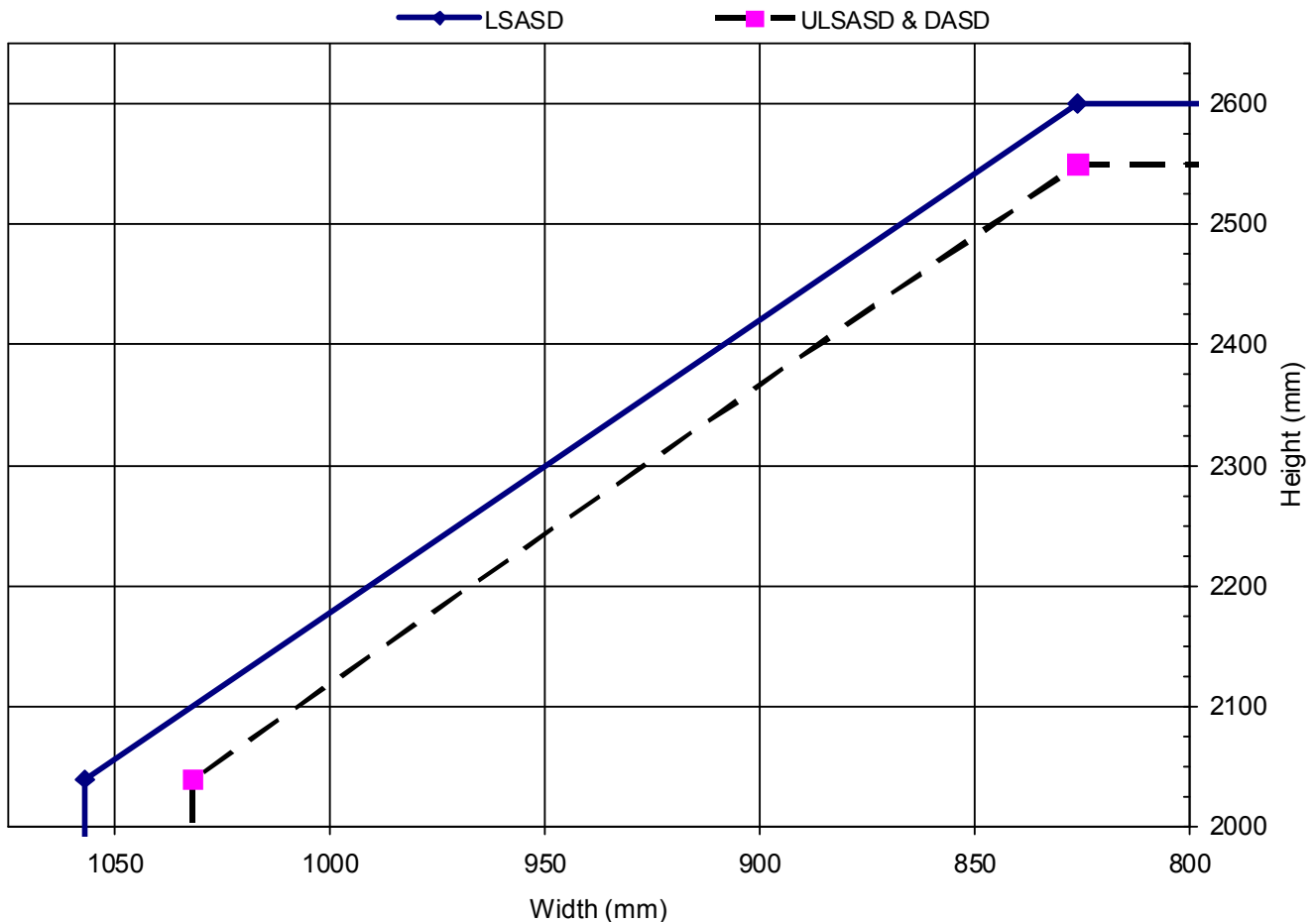

The legal validity of this report can only be claimed on presentation of the complete report.

Pacific Rim Wood Ltd – ‘Flamebreak’ 30 Doorsets

Latched & Unlatched Single Acting & Double Acting Single Doorsets – Pyroplex Rigid Box Seal

Facing Type: 3.6mm Plywood					
Leaf Sizes	Configuration	Height (mm)			Width (mm)
	LSASD	From:	2040	x	919
		To:	2260	x	826
ULSASD & DASD	From:	2040	x	894	
	To:	2210	x	826	
Maximum Overpanel height (mm)	Transomed	2000			
Glazing	Maximum Glazed Area:	1.15m ² (see section 7 for details)			
	Approved systems:	See section 7 and appendix B			
Frame specification	Min. Section (mm):	70 x 32	70 x 32	70 x 30	
	Material:	Softwood	Hardwood	MDF	
	Min. Density (kg/m ³):	510	510	700	
<p>Intumescent Materials: PVC encapsulated Pyroplex Rigid Box Seal</p> <p>Head: 1 No 10 x 4mm fitted centrally in the leaf edge or frame reveal.</p> <p>Jambs: 1 No 10 x 4mm fitted centrally in the leaf edge or frame reveal.</p> <p>Hardware Protection: see section 11</p>					

Maximum Door Leaf Size

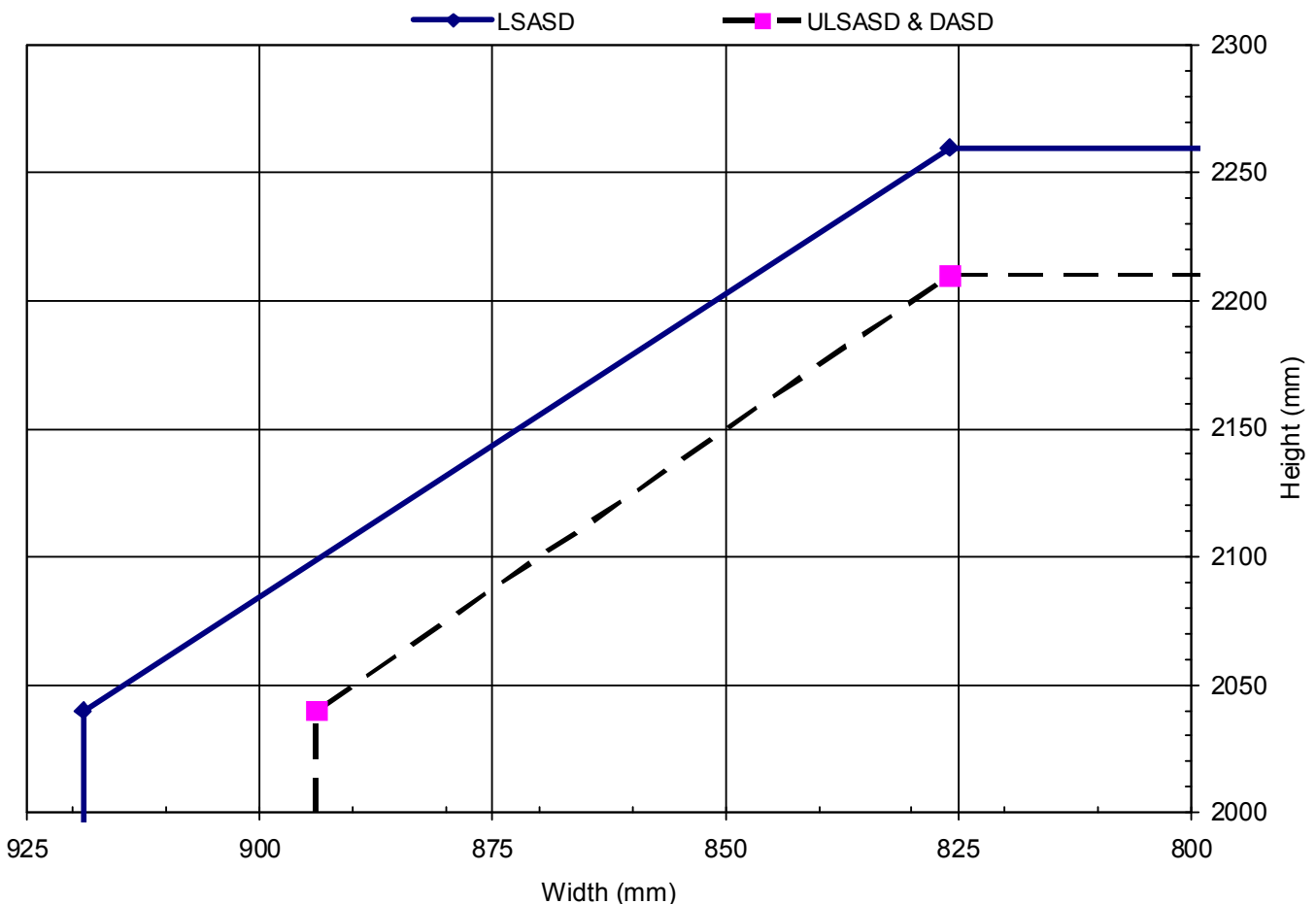

The legal validity of this report can only be claimed on presentation of the complete report.

Pacific Rim Wood Ltd – ‘Flamebreak’ 30 Doorsets

Latched & Unlatched Single Acting & Double Acting Single Doorsets – Pyroplex Rigid Box Seal

Facing Types: 3.6mm Plywood, 6mm Plywood, 6mm MDF					
Leaf Sizes	Configuration	Height (mm)			Width (mm)
	LSASD	From:	2400	x	1358
		To:	3190	x	1000
ULSASD & DASD	From:	2400	x	1333	
	To:	3140	x	1000	
Maximum Overpanel height (mm)	Transomed	2000			
Glazing	Maximum Glazed Area:	1.15m ² (see section 7 for details)			
	Approved systems:	See section 7 and appendix B			
Frame specification	Min. Section (mm):	70 x 32	70 x 32	70 x 30	
	Material:	Softwood	Hardwood	MDF	
	Min. Density (kg/m ³):	510	510	700	
<p>Intumescent Materials: PVC encapsulated Pyroplex Rigid Box Seal</p> <p>Head: 2 No 10 x 4mm fitted centrally 10mm apart in the leaf edge or frame reveal.</p> <p>Jambs: 2 No 10 x 4mm fitted centrally 10mm apart in the leaf edge or frame reveal.</p> <p>Hardware Protection: see section 11</p>					

Maximum Door Leaf Size

—◆— LSASD —■— ULSASD & DASD

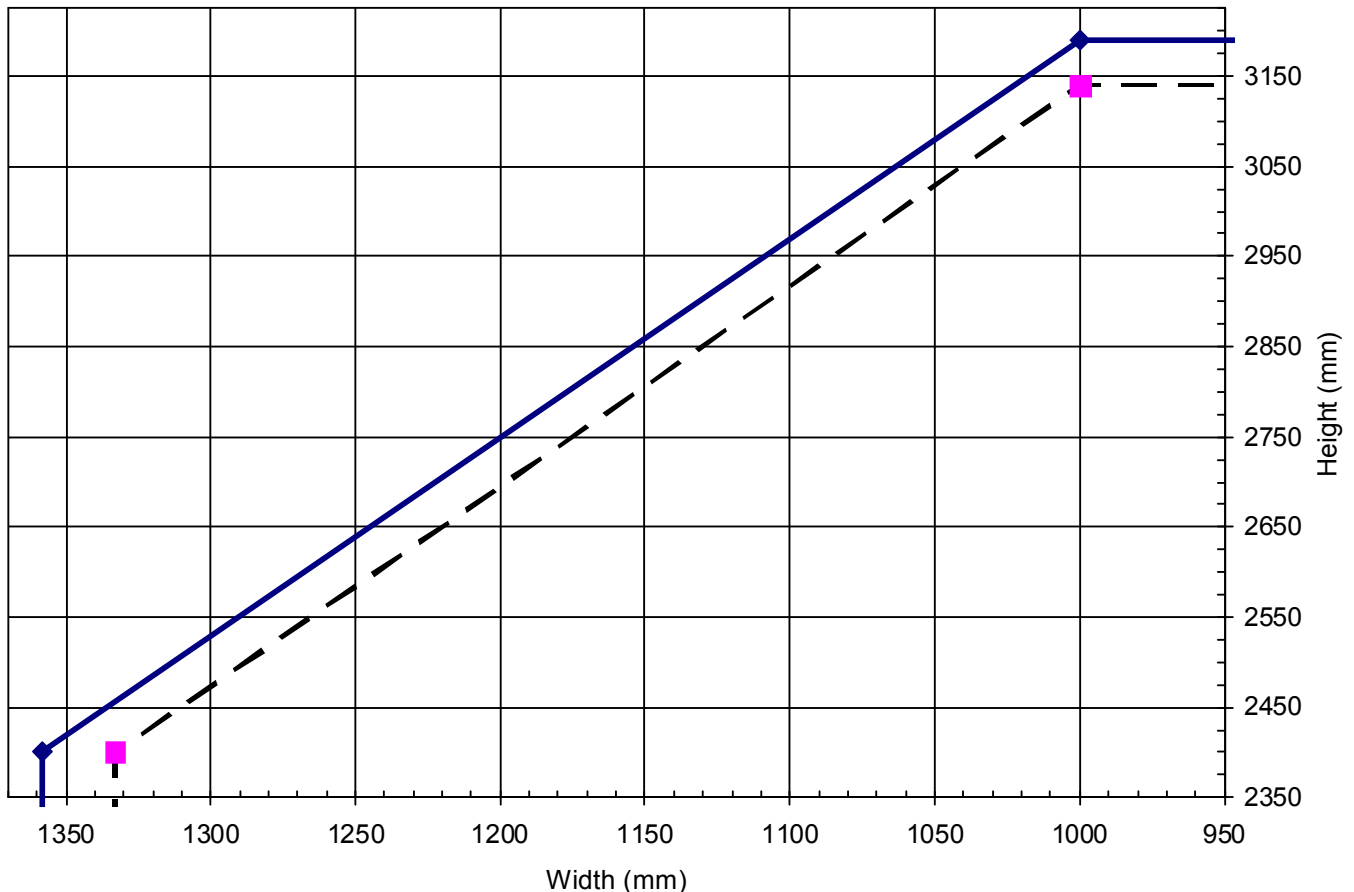

The legal validity of this report can only be claimed on presentation of the complete report.

Pacific Rim Wood Ltd – ‘Flamebreak’ 30 Doorsets
Latched & Unlatched Single Acting & Double Acting Single Doorsets + Overpanel –
Pyroplex Rigid Box Seal

Facing Type: 3.6mm Plywood						
Leaf Sizes	Configuration		Height (mm)		Width (mm)	
	LSASD + OP	From:	2400	x	1308	
		To:	3090	x	1000	
ULSASD & DASD + OP	From:	2400	x	1283		
	To:	3040	x	1000		
Maximum Overpanel height (mm)			2000			
Glazing	Maximum Glazed Area:	1.15m ² (see section 7 for details)				
	Approved systems:	See section 7 and appendix B				
Frame specification	Min. Section (mm):	70 x 32	70 x 32	70 x 30		
	Material:	Softwood	Hardwood	MDF		
	Min. Density (kg/m ³):	510	510	700		
Intumescent Materials: PVC encapsulated Pyroplex Rigid Box Seal						
Head: 2 No 10 x 4mm fitted centrally in the leaf edge or frame reveal.						
Jamb: 2 No 10 x 4mm fitted centrally in the leaf edge or frame reveal.						
Hardware Protection: see section 11						

Maximum Door Leaf Size

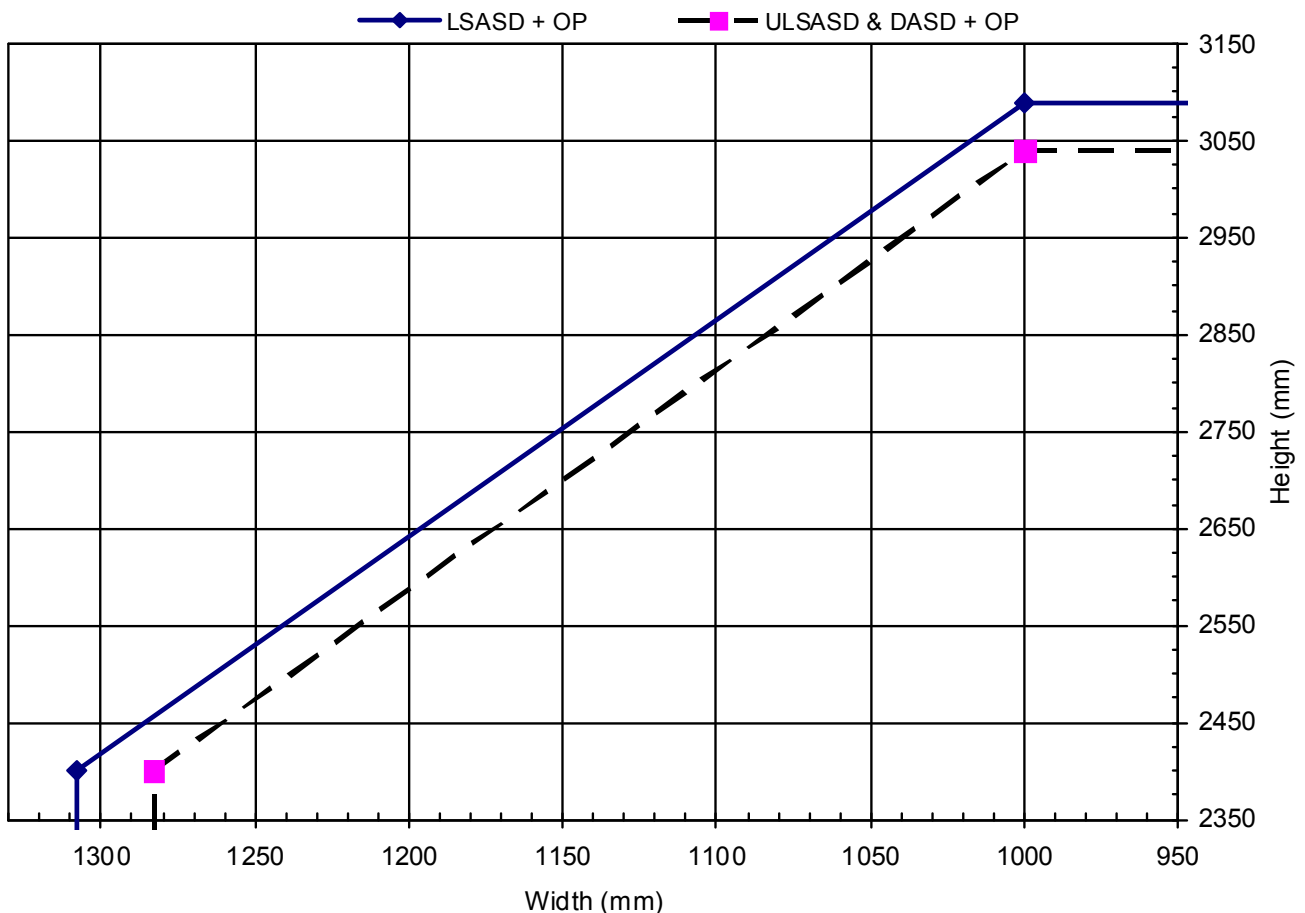

The legal validity of this report can only be claimed on presentation of the complete report.

Pacific Rim Wood Ltd – ‘Flamebreak’ 30 Doorsets
Latched Single Acting Double Doorsets – Palusol or Type 617

Leaf Sizes	Facing Type	Height (mm)			Width (mm)
	3.6mm thick Plywood	From: 2135 To: 2434	x	x	1047 915
All other assessed facing types	From: 2135 To: 2252	x	x	969 915	
	Maximum Overpanel height (mm)	Transomed	1500		
Glazing	Maximum Glazed Area:	1.15m ² (see section 7 for details)			
	Approved systems:	See section 7 and appendix B			
Frame specification	Min. Section (mm):	70 x 32	70 x 32	70 x 30	
	Material:	Softwood	Hardwood	MDF	
	Min. Density (kg/m ³):	510	510	700	

Intumescent Materials: PVC encapsulated Palusol 100 or Type 617

Head: 1 No 20 x 4mm seal fitted centrally in the leaf edge or frame reveal.

Jambs: 1 No 20 x 4mm seal fitted centrally in the leaf edge or frame reveal.

Meeting Edges:
Square - 1 No 20 x 4mm seal fitted centrally in one meeting edge.
Rebated - 1 No 10 x 4mm seal fitted centrally in the rebate of both leaf edges.

Hardware Protection: see section 11

Maximum Door Leaf Size

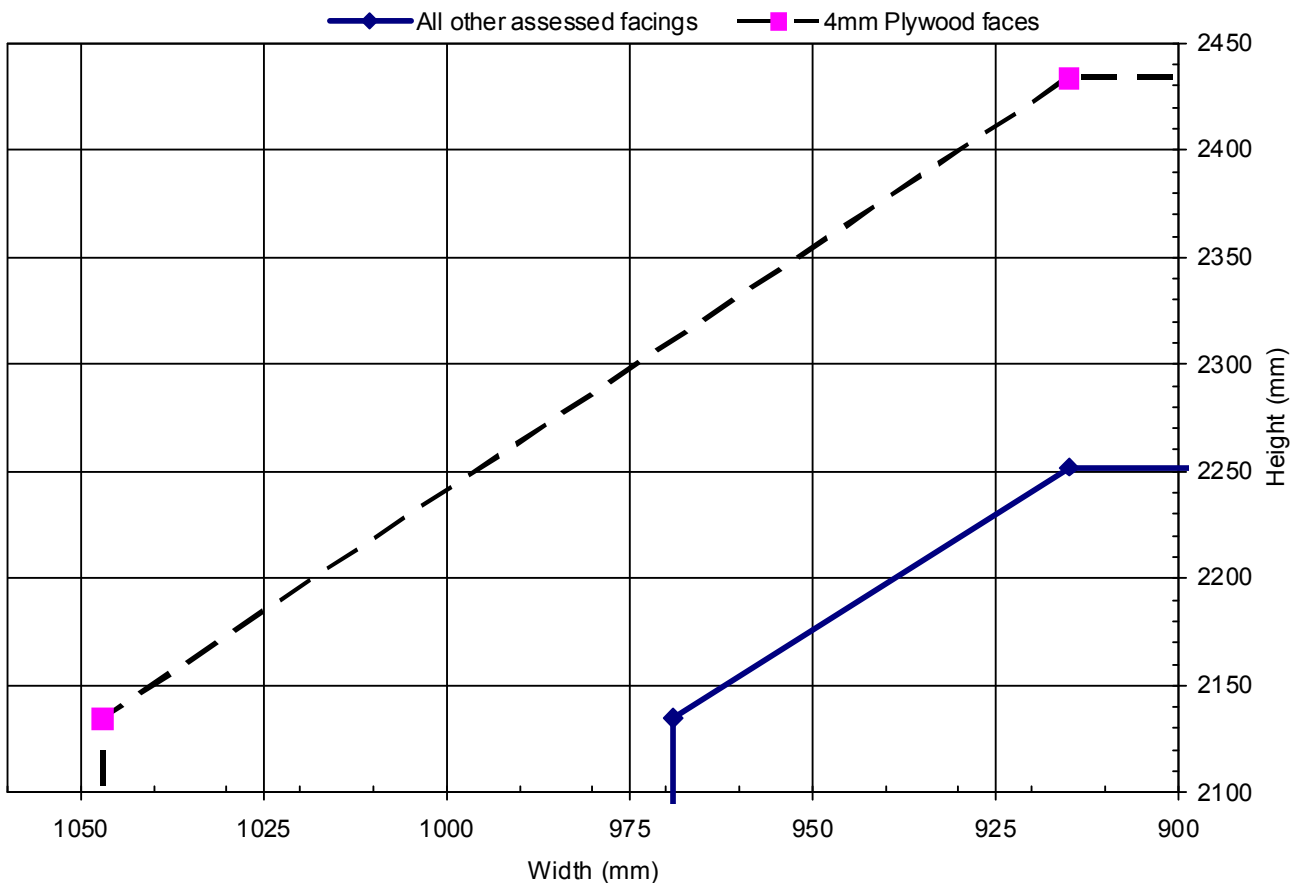

The legal validity of this report can only be claimed on presentation of the complete report.

Pacific Rim Wood Ltd – ‘Flamebreak’ 30 Doorsets

Unlatched Single Acting & Double Acting Double Doorsets – Palusol or Type 617

Leaf Sizes	Facing Type	Height (mm)			Width (mm)		
	3.6mm thick Plywood	From: To:	2135 2384	x x	1022 915		
All other assessed facing types	From: To:	2135 2202	x x	944 915			
	Maximum Overpanel height (mm)	Transomed	1500				
Glazing	Maximum Glazed Area:	1.15m ² (see section 7 for details)					
	Approved systems:	See section 7 and appendix B					
Frame specification	Min. Section (mm):	70 x 32	70 x 32	70 x 30			
	Material:	Softwood	Hardwood	MDF			
	Min. Density (kg/m ³):	510	510	700			
Intumescent Materials: PVC encapsulated Palusol 100 or Type 617							
Head: 1 No 20 x 4mm seal fitted centrally in the leaf edges or frame reveal.							
Jambs: 1 No 20 x 4mm seal fitted centrally in the leaf edges or frame reveal.							
Meeting Edges:							
Square - 1 No 20 x 4mm seal fitted centrally in one meeting edge.							
Rebated -1 No 10 x 4mm seal fitted centrally in the rebate of both leaf edges.							
Hardware Protection: see section 11							

Maximum Door Leaf Size

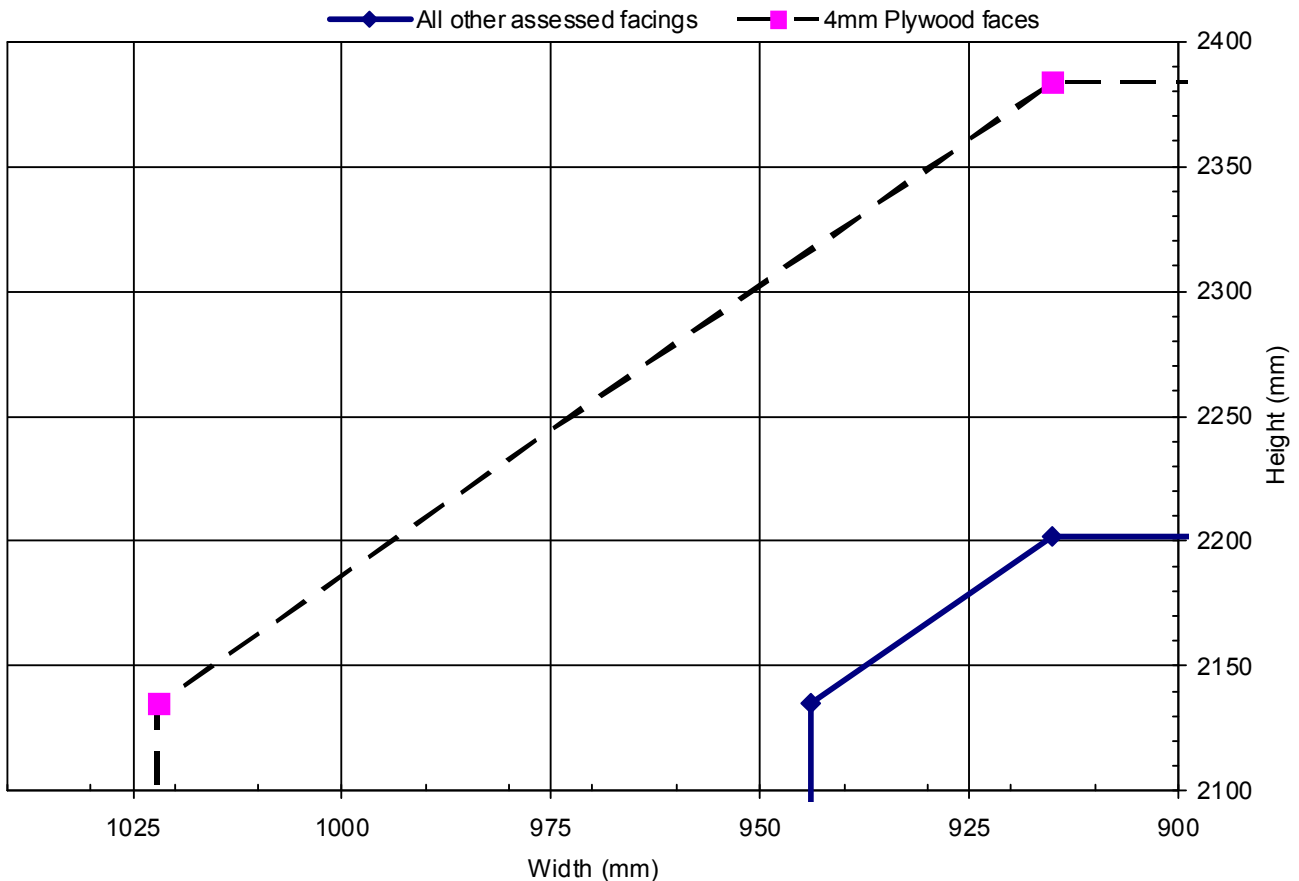

The legal validity of this report can only be claimed on presentation of the complete report.

**Pacific Rim Wood Ltd – ‘Flamebreak’ 30 Doorsets
Latched & Unlatched Single Acting & Double Acting Double Doorsets –
Pyroplex Rigid Box Seal**

Facing Types: 3.6mm Plywood, 6mm Plywood, 6mm MDF					
Leaf Sizes	Configuration		Height (mm)		Width (mm)
	LSADD	From:	2400	x	1258
		To:	2990	x	1000
	ULSADD & DADD	From:	2400	x	1233
To:		2940	x	1000	
Maximum Overpanel height (mm)	Transomed	1500			
Glazing	Maximum Glazed Area:	1.15m ²			
	Approved systems:	See section 7 and appendix B			
Frame specification	Min. Section (mm):	70 x 32	70 x 32	70 x 30	
	Material:	Softwood	Hardwood	MDF	
	Min. Density (kg/m ³):	510	510	700	
Intumescent Materials: PVC encapsulated Pyroplex Rigid Box Seal					
Head: 2 No 10 x 4mm PVC encapsulated Pyroplex fitted centrally 10mm apart in the leaf edge or frame head.					
Jambs: 2 No 10 x 4mm PVC encapsulated Pyroplex fitted centrally 10mm apart in the each leaf edge or frame reveal.					
Meeting Edges: 2 No 10 x 4mm PVC encapsulated Pyroplex fitted centrally 10mm apart in one leaf edge only.					
Hardware Protection: see section 11					

Maximum Door Leaf Size

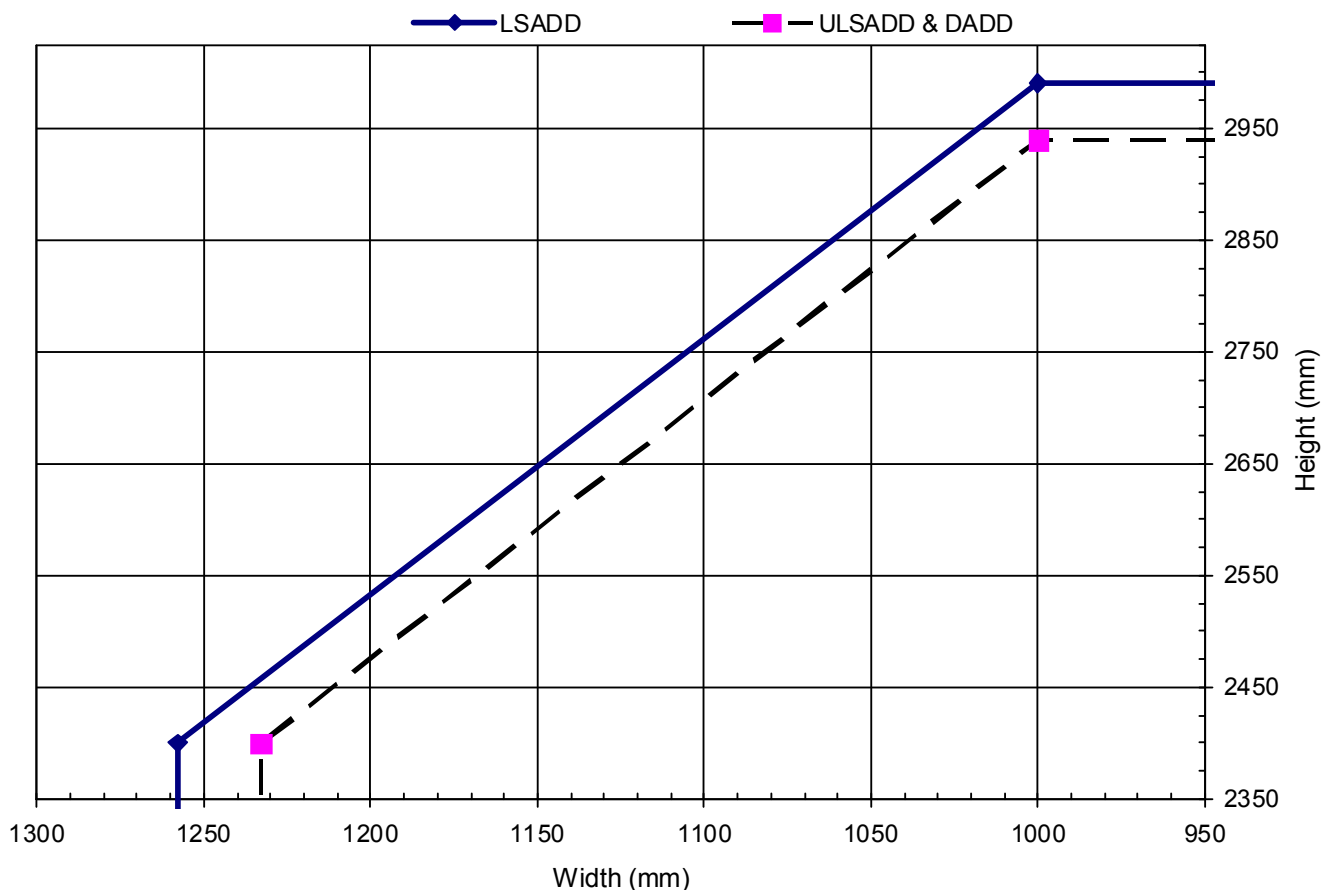

The legal validity of this report can only be claimed on presentation of the complete report.

Pacific Rim Wood Ltd – ‘Flamebreak’ 30 Doorsets
Latched & Unlatched Single Acting & Double Acting Double Doorsets + Overpanels –
Pyroplex Rigid Box Seal

Facing Types: 3.6mm Plywood						
Leaf Sizes	Configuration		Height (mm)		Width (mm)	
	LSADD + OP	From:	2400	x	1208	
		To:	2890	x	1000	
ULSADD & DADD + OP	From:	2400	x	1183		
	To:	2840	x	1000		
Maximum Overpanel height (mm)			1500			
Glazing	Maximum Glazed Area:	1.15m ²				
	Approved systems:	See section 7 and appendix B				
Frame specification	Min. Section (mm):	70 x 32	70 x 32	70 x 30		
	Material:	Softwood	Hardwood	MDF		
	Min. Density (kg/m ³):	510	510	700		
Intumescent Materials: PVC encapsulated Pyroplex Rigid Box Seal						
Head:						
Square - 2 No 10 x 4mm PVC encapsulated Pyroplex fitted centrally 10mm apart in the leaf edge or bottom of overpanel.						
Rebated:						
Leaves - 2 No 10 x 4mm with one strip centrally fitted on the top of the upstand of the rebate and one centrally in the bottom of the rebate.						
Transom - 1 No 10 x 4mm strip centrally fitted in the bottom of the overpanel rebate.						
Jambs: 2 No 10 x 4mm PVC encapsulated Pyroplex fitted centrally 10mm apart in the each leaf edge or frame reveal.						
Meeting Edges: 2 No 10 x 4mm PVC encapsulated Pyroplex fitted centrally 10mm apart in one leaf edge only.						
Hardware Protection: see section 11						

Maximum Door Leaf Size

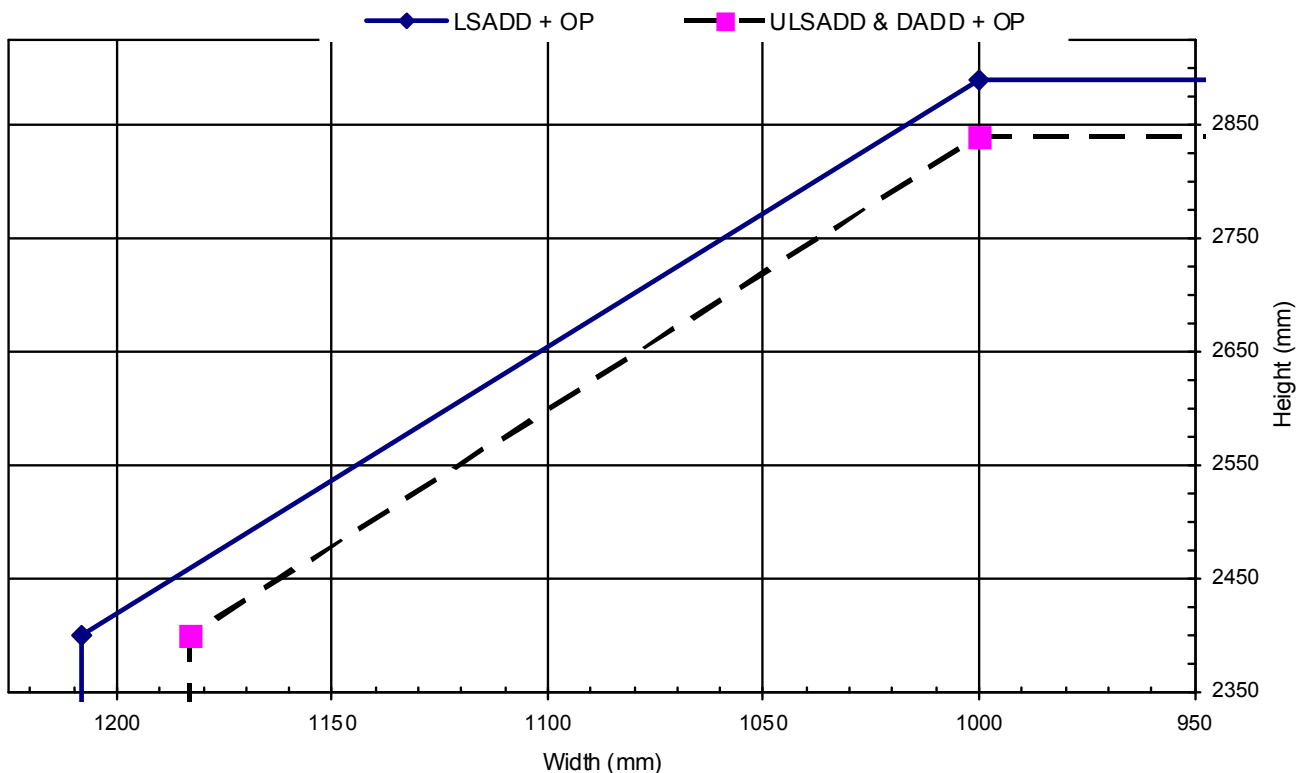

The legal validity of this report can only be claimed on presentation of the complete report.